

# N25 1" Full Flow High Pressure Pumps Specifications and Performance

## SPECIFICATIONS

N25

**FLOW RATE** (Adjustable) ..... 0-30 gpm (125 lpm)  
**PORT SIZE**  
 Inlet and Outlet..... 1.0" NPTF  
**AIR INLET** ..... 0.50" NPTF  
**AIR EXHAUST** ..... 0.375" BSP  
**SUCTION LIFT** ... 20' Dry/25' Wet (6.09m/7.62m)  
**MAX. PARTICLE SIZE** (Diameter) ..... 0.125"(3mm)  
**SHIPPING WEIGHT**  
 Aluminum..... 88 lbs (40 kg)  
 Stainless Steel ..... 110 lbs (50 kg)



## PERFORMANCE

Determined by actual flow meter tests.

N25

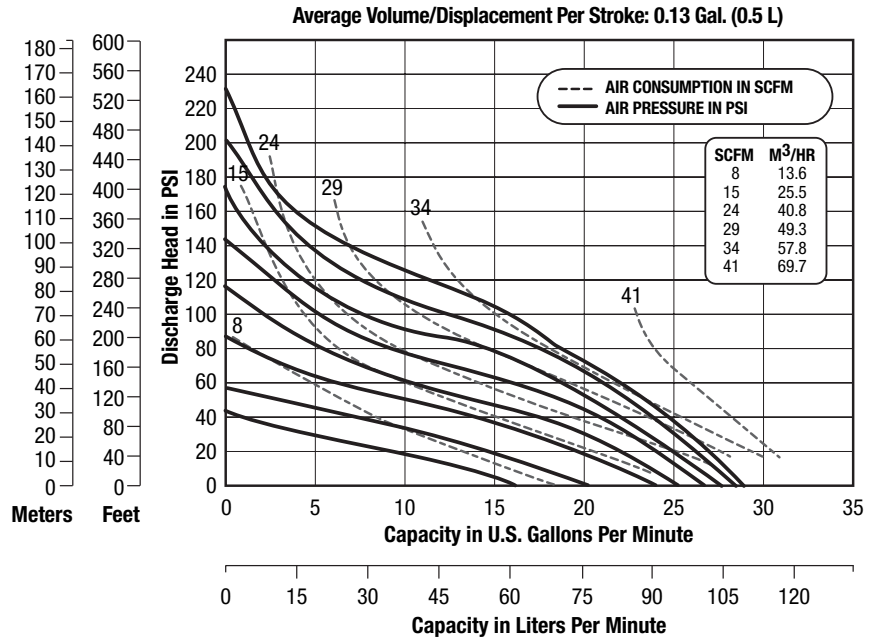

**CAUTION:** Do not exceed 100 psig (6.9 bars) air supply or liquid pressure. ??????????

## DIMENSIONS

Consult factory for certified drawings.

N25

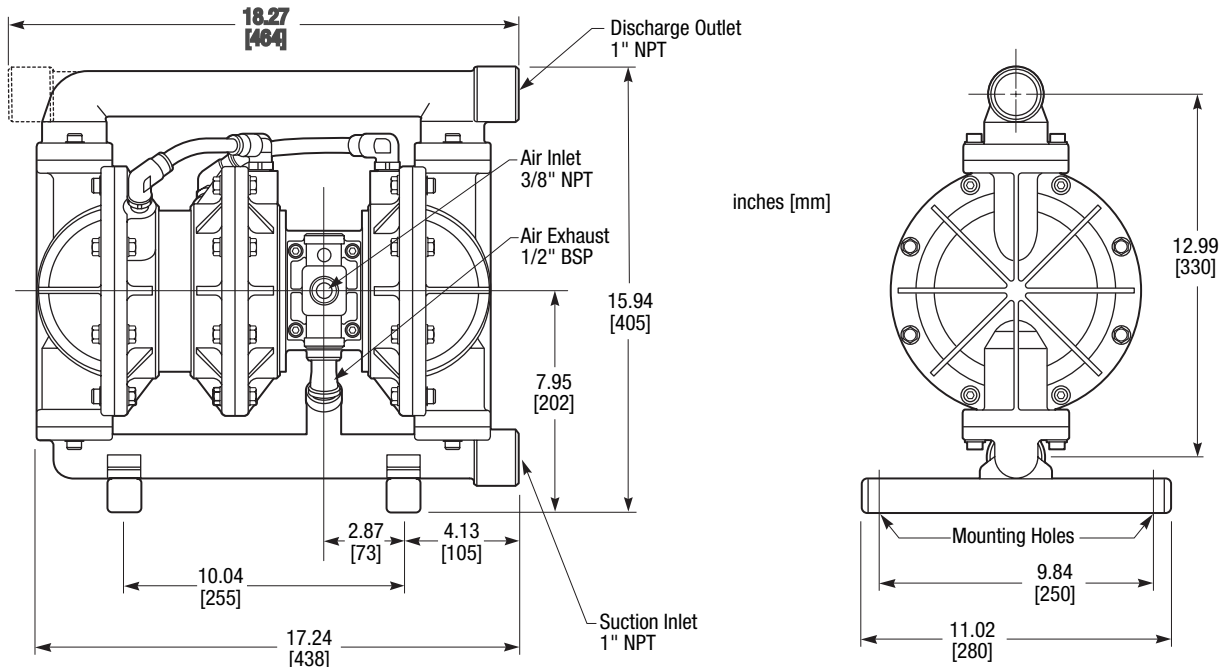

# N50 2" Full Flow High Pressure Pumps Specifications and Performance

## SPECIFICATIONS

N50

**FLOW RATE** (Adjustable) ..... 0-90 gpm (34 lpm)

**PORT SIZE**

Inlet and Outlet ..... 2.0" NPTF

**AIR INLET** ..... 0.75" NPTF

**AIR EXHAUST** ..... 0.75" BSP

**SUCTION LIFT** ... 20' Dry/25' Wet (6.09m/7.62m)

**MAX. PARTICLE SIZE** (Diameter) ..... 0.25"(6mm)

**SHIPPING WEIGHT**

Aluminum ..... 147 lbs (67 kg)

Stainless Steel ..... 165 lbs (75 kg)

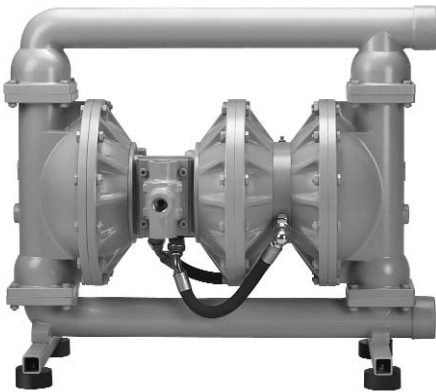

## PERFORMANCE

Determined by actual flow meter tests.

N50

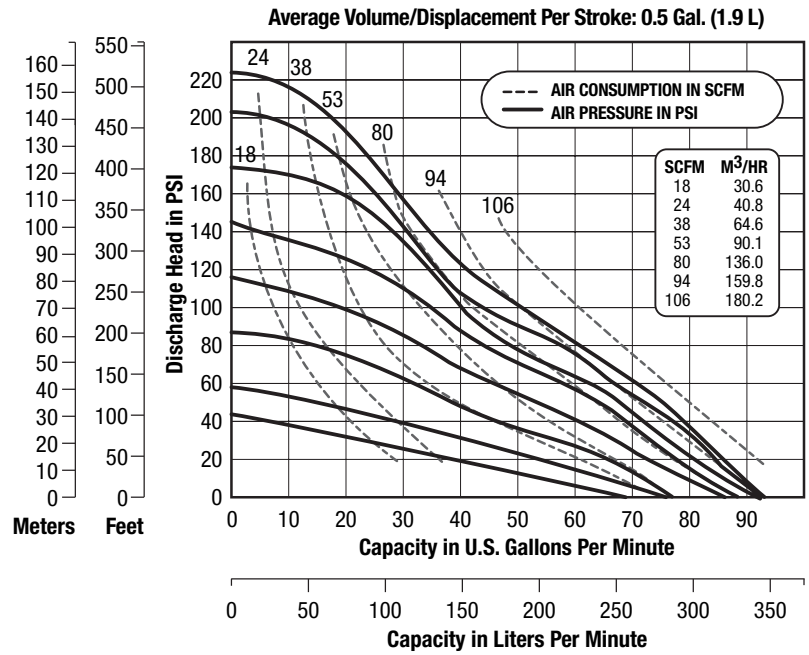

**CAUTION:** Do not exceed 100 psig (6.9 bars) air supply or liquid pressure.?????????

## DIMENSIONS

Consult factory for certified drawings.

N50

