

SERVICE & OPERATING MANUAL

VERSA-MATIC®

Model E6 Non-Metallic Ball Valve

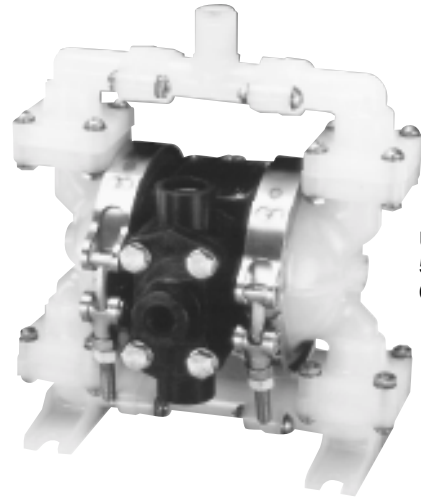

U.S. Patent #
5,996,627 and
6,241,487

Table of Contents

Engineering Data and Temperature Limitations	1
Performance Curves	1
Explanation of Pump Nomenclature	2
Dimensions	3
Metric Dimensions	4
Principle of Pump Operation	5
Check Valve Servicing	5
Diaphragm Servicing	5
Troubleshooting	6
Warranty	6
Recycling	6
Important Safety Information	6
Material Codes	7
Installation Guide	7
Composite Repair Parts Drawing	8
Available Service and Conversion Kits	8
Composite Repair Parts List	9
Grounding the Pump	9
Solenoid Shifted Option Drawing	10
Solenoid Shifted Air Valve Parts List	10
Solenoid Shifted Options	11
Solenoid Connector Drawing	11

OMATIC®

**Metallic
Ball Valve**

**Powered
Pump**

Performance
Data

Available Pump Models

E6 Non-Metallic

MODEL TYPE	Pump Size	Wetted Material	Non-Wetted Material	Diaphragm Material	Diaphragm Series	Valve Ball Material	Wetted Seals	Type of Construction	Options
E6PP6X650	6	P	P	6	X	6	5	0	–
E6PP6X550	6	P	P	6	X	5	5	0	–
E6PP5B550	6	P	P	5	B	5	5	0	–
E6KP6X650	6	K	P	6	X	6	5	0	–
E6KP6X550	6	K	P	6	X	5	5	0	–
E6KP5B550	6	K	P	5	B	5	5	0	–
E6GG6X650	6	G	G	6	X	6	5	0	–
E6GG6X550	6	G	G	6	X	5	5	0	–
E6GG5B550	6	G	G	5	B	5	5	0	–
E6PP6X650-E0	6	P	P	6	X	6	5	0	E0
E6PP6X650-E1	6	P	P	6	X	6	5	0	E1
E6PP6X650-E2	6	P	P	6	X	6	5	0	E2
E6PP6X650-E3	6	P	P	6	X	6	5	0	E3
E6PP6X650-E4	6	P	P	6	X	6	5	0	E4
E6PP6X650-E5	6	P	P	6	X	6	5	0	E5
E6PP6X650-E6	6	P	P	6	X	6	5	0	E6
E6PP6X650-E7	6	P	P	6	X	6	5	0	E7

Explanation of Pump Nomenclature:

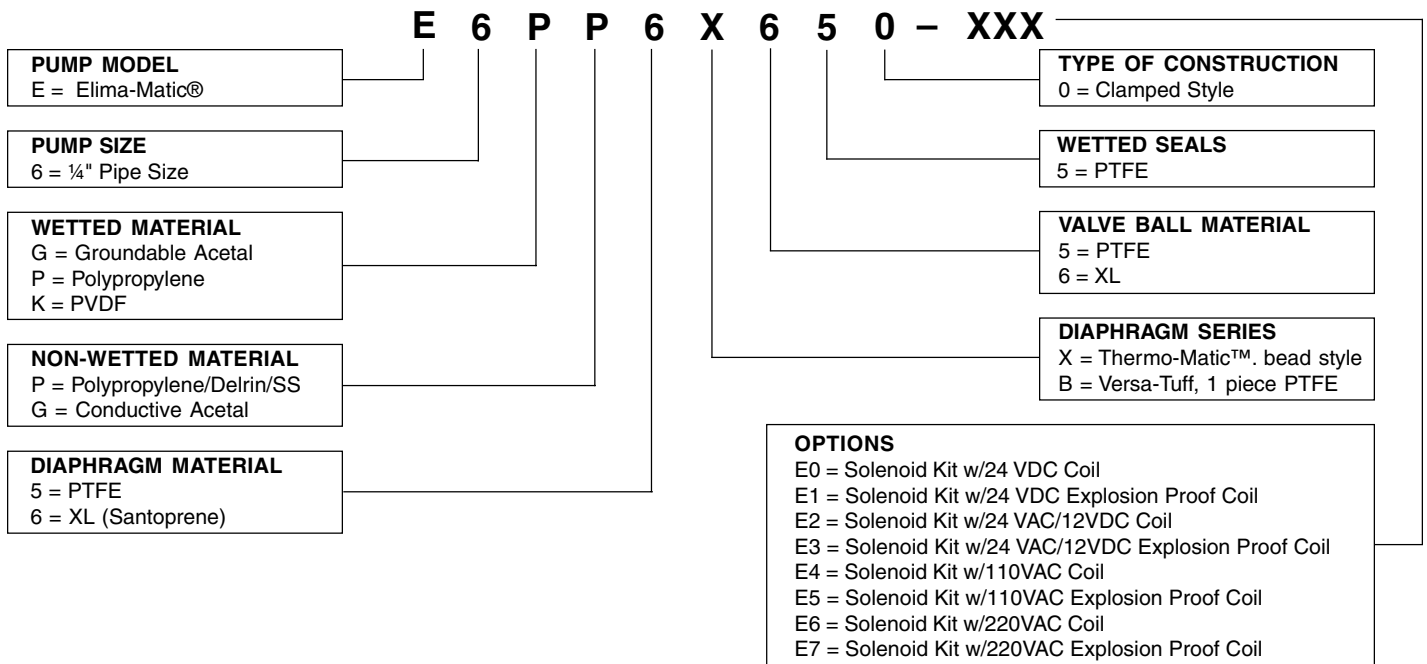

Dimensions: E6 Non-Metallic

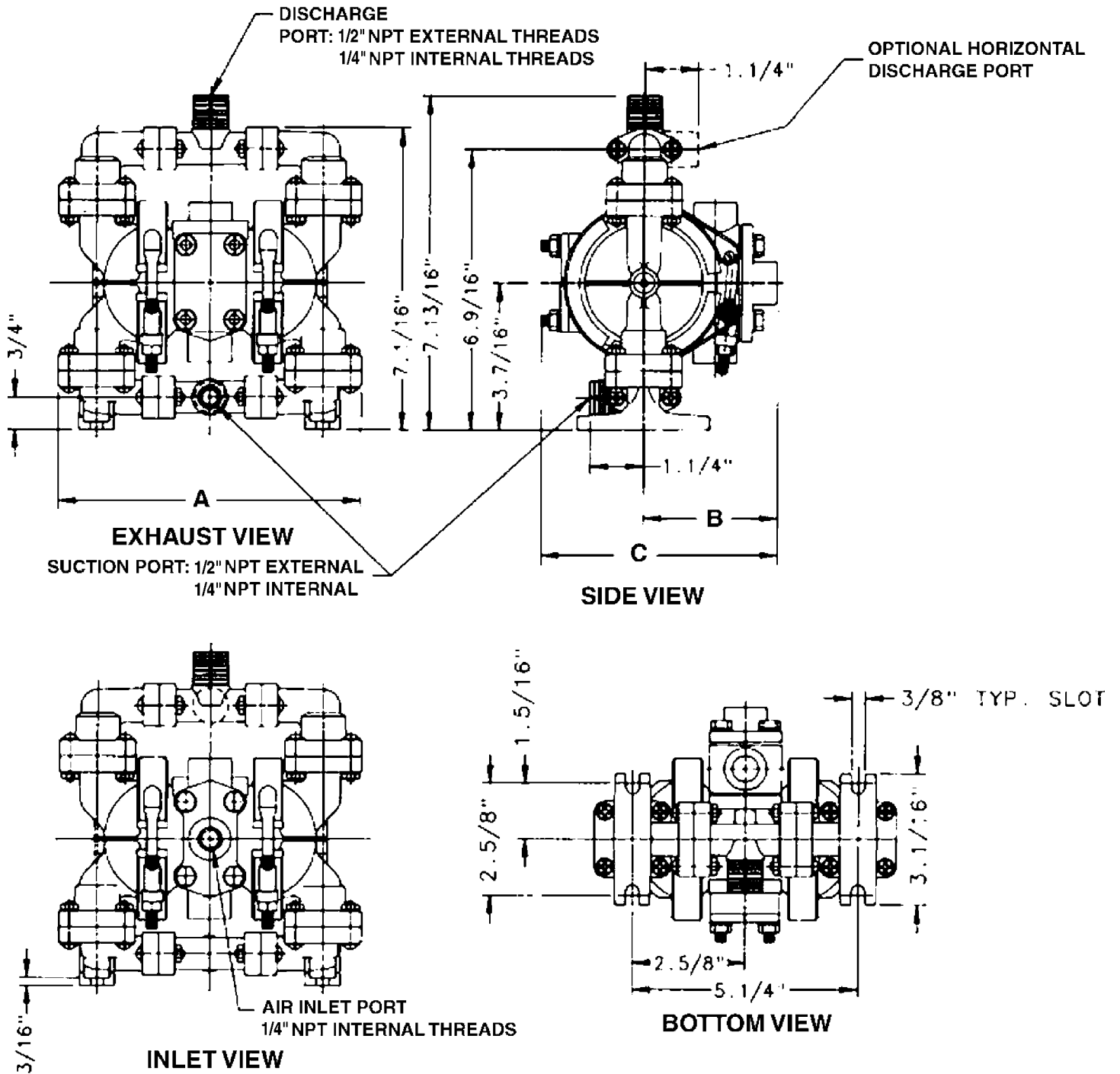

Dimension	A	B	C
Standard	7"	3.1/8"	5.1/2"
Pulse Output Kit	9"	3.9/16"	5.15/16"

Metric Dimensions: E6 Non-Metallic

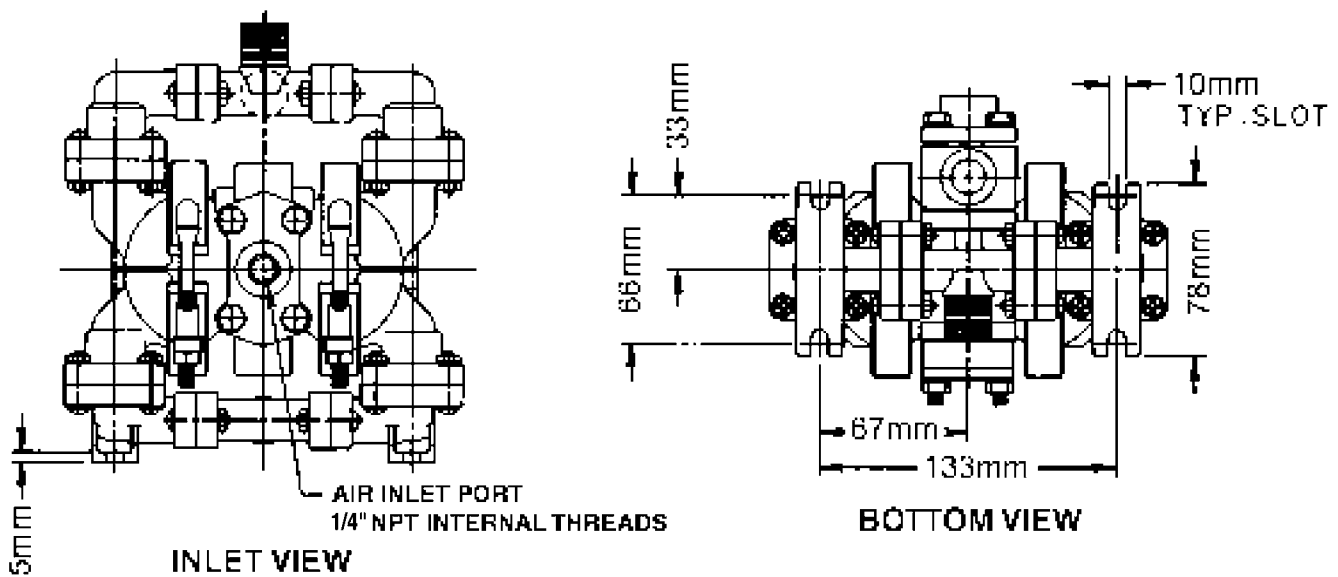
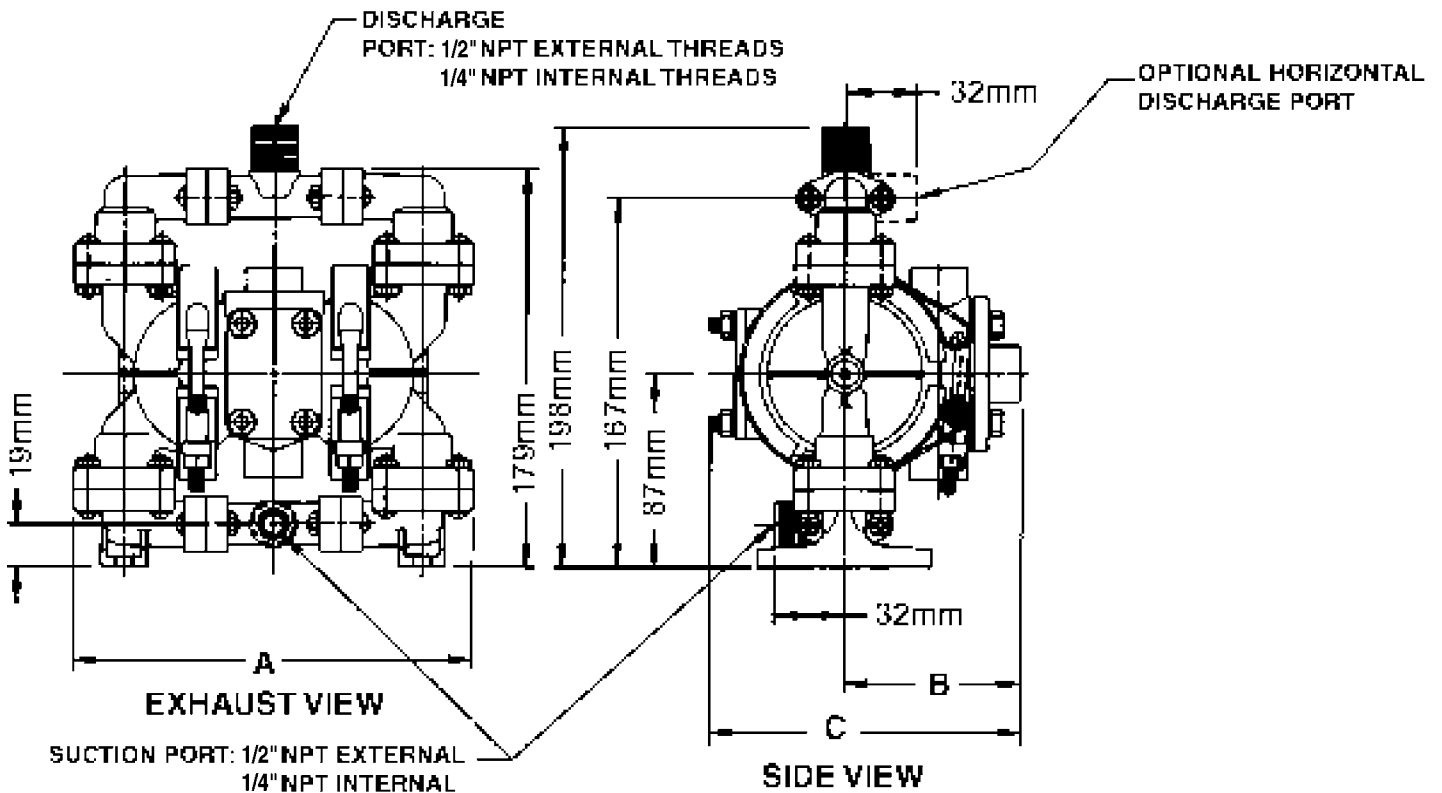

Dimension	A	B	C
Standard	178	79	140
Pulse Output Kit	229	90	151

PRINCIPLE OF PUMP OPERATION

This ball type check valve pump is powered by compressed air and is a 1:1 ratio design. The inner side of one diaphragm chamber is alternately pressurized while simultaneously exhausting the other inner chamber. This causes the diaphragms, which are connected by a common rod secured by plates to the centres of the diaphragms, to move in a reciprocating action. (As one diaphragm performs the discharge stroke the other diaphragm is pulled to perform the suction stroke in the opposite chamber.) Air pressure is applied over the entire inner surface of the diaphragm while liquid is discharged from the opposite side of the diaphragm. The diaphragm operates in a balanced condition during the discharge stroke which allows the pump to be operated at discharge heads over 200 feet (61 meters) of water.

For maximum diaphragm life, keep the pump as close to the liquid being pumped as possible. Positive suction head in excess of 10 feet of liquid (3.048 meters) may require a back pressure regulating device to maximize diaphragm life.

Alternate pressurizing and exhausting of the diaphragm chamber is performed by an externally mounted, pilot operated, four way spool type air distribution valve. When the spool shifts to one end of the valve body, inlet pressure is applied to one diaphragm chamber and the other diaphragm chamber exhausts. When the spool shifts to the opposite end of the valve body, the pressure to the chambers is reversed. The air distribution valve spool is moved by an internal pilot valve which alternately pressurizes one end of the air distribution valve spool while exhausting the other end. The pilot valve

is shifted at each end of the diaphragm stroke when an actuator plunger is contacted by the diaphragm plate. This actuator plunger then pushes the end of the pilot valve spool into position to activate the air distribution valve.

The chambers are connected with manifolds with a suction and discharge check valve for each chamber, maintaining flow in one direction through the pump.

INSTALLATION AND START-UP

Locate the pump as close to the product being pumped as possible. Keep the suction line length and number of fittings to a minimum. Do not reduce the suction line diameter.

For installations of rigid piping, short sections of flexible hose should be installed between the pump and the piping. The flexible hose reduces vibration and strain to the pumping system. A surge suppressor is recommended to further reduce pulsation in flow.

AIR SUPPLY

Air supply pressure cannot exceed 100 psi (8.6 bar). Connect the pump air inlet to an air supply of sufficient capacity and pressure required for desired performance. When the air supply line is solid piping, use a short length of flexible hose not less than 1/2" (13mm) in diameter between the pump and the piping to reduce strain to the piping. The weight of the air supply line, regulators and filters must be supported by some means other than the air inlet cap. Failure to provide support for the piping may result in damage to the pump. A pressure regulating valve should be installed to insure air supply pressure does not exceed recommended limits.

CHECK VALVE SERVICING

Need for inspection or service is usually indicated by poor priming, unstable cycling, reduced performance or the pump's cycling but not pumping.

Remove the sixteen machine screws securing the manifold assemblies to the outer chambers. Inspect the surfaces of both check valve and seat for wear or damage that could prevent proper sealing. If pump is to prime properly, valves must seat air tight.

DIAPHRAGM SERVICING

Remove the two V-Band clamps securing the outer chambers to the intermediate housing. Remove the diaphragm assembly (outer plate, diaphragm, inner plate) by turning the assembly counterclockwise using a 1/2" (1.27 cm) wrench on the outer plate lugs. (If a socket is used, it must be a six point socket.) The interior components consisting of the shaft seal and pilot valve assembly are now accessible for service.

Procedures for reassembling the diaphragms are the reverse of the above. Install the diaphragm with the natural bulge outward.

Install the outer diaphragm plate on the outside of the diaphragm and make certain that the large radius side of the inner plate is toward the diaphragm. Tighten the outer diaphragm plate to approximately 30 in./lbs. (3.39 Newton meters).

Torque while allowing the diaphragm to turn freely with plates. Use a wrench on the outer diaphragm plate of the opposite side to keep rod from rotating. If the opposite chamber is assembled, the rod need not be held.

AIR VALVE LUBRICATION

The air distribution valve and the pilot valve are designed to operate WITH-OUT lubrication. This is the preferred mode of operation. There may be instances of personal preference or poor quality air supplies when lubrication of the compressed air supply is required. The pump air system will operate with properly lubricated compressed air supply. Proper lubrication requires the use of an air line lubricator (available from Versa-Matic) set to deliver one drop of SAE 10 non-detergent oil for every 20 SCFM (9.4 liters/sec.) of air the pump consumes at the point of operation. Consult the pump's published Performance Curve to determine this.

AIR LINE MOISTURE

Water in the compressed air supply can create problems such as icing or freezing of the exhaust air, causing the pump to cycle erratically or stop operating. Water in the air supply can be reduced by using a point-of-use air dryer to supplement the user's air drying equipment. This device removes water from the compressed air supply and alleviates the icing or freezing problems.

AIR INLET AND PRIMING

To start the pump, open the air valve approximately 1/2 to 3/4 turn. After the pump primes, the air valve can be opened to increase air flow as desired. If opening the valve increases cycling rate, but does not increase the rate of flow, cavitation has occurred. The valve should be closed slightly to obtain the most efficient air flow to pump flow ratio.

SERVICING THE PILOT VALVE

To remove the pilot valve spool (item 23) first remove the end o-ring (item 24) from one end of spool. Slide the spool out of the sleeve and inspect the five remaining o-rings (items 24) for damage or wear. If necessary, replace damaged o-rings. Inspect the inner diameter of pilot valve sleeve (item 20) for scratches, dirt, or other contaminants. Replace the sleeve if necessary. To remove the sleeve first remove the retaining ring from one end. When installing a pilot valve sleeve first lightly grease the six o-rings (items 21). Insert the sleeve into the chamfered end of bore on the intermediate bracket (item 13). Push the sleeve in until the shoulder is flush to intermediate bracket surface and install the retaining ring (item 22). To install the pilot valve spool first lightly grease the four interior o-rings and insert into the pilot valve sleeve. After inserting the spool into the sleeve install the remaining loose o-rings onto spool.

SERVICING DIAPHRAGM ROD SEALS

To service the rod seals (item 18) first remove pilot valve, then remove the inserts on each of the intermediate brackets (item 17) by prying them out with a small flat screwdriver. After removing the inserts take the K-R rod seals out of the inserts and replace. When reinstalling the seals, make sure the open side of the seals face into the counterbore in the inserts. To install the inserts into intermediate bracket, simply press the insert into the counterbore in each of the intermediate bracket, making sure that the closed side of insert faces out. The inserts should be flush to the surface of the intermediate bracket or slightly below the surface when fully installed.

BETWEEN USES

When the pump is used for materials that tend to settle out or solidify when not in motion, the pump should be flushed after each use to prevent damage. (Product remaining in the pump between uses could dry out or settle out. This could cause problems with the diaphragms and check valves at restart.) In freezing temperatures the pump must be completely drained between uses in all cases.

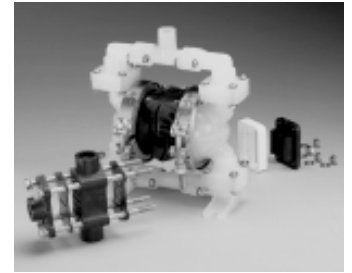

Figure 1



Figure 2



Figure 3



Figure 4

TROUBLESHOOTING

Possible Symptoms:

- Pump will not cycle.
- Pump cycles, but produces no flow.
- Pump cycles, but flow rate is unsatisfactory.
- Pump cycle seems unbalanced.
- Pump cycle seems to produce excessive vibration.

What to Check: Excessive suction lift in system.

Corrective Action: For lifts exceeding 20 feet (6 meters), filling the pumping chambers with liquid will prime the pump in most cases.

What to Check: Excessive flooded suction in system.

Corrective Action: For flooded conditions exceeding 10 feet (3 meters) of liquid, install a back pressure device.

What to Check: System head exceeds air supply pressure.

Corrective Action: Increase the inlet air pressure to the pump. Most diaphragm pumps are designed for 1:1 pressure ratio at zero flow.

What to Check: Air supply pressure or volume exceeds system head.

Corrective Action: Decrease inlet air pressure and volume to the pump as calculated on the published PERFORMANCE CURVE. Pump is cavitating the fluid by fast cycling.

What to Check: Undersized suction line.

Corrective Action: Meet or exceed pump connection recommendations shown on the DIMENSIONAL DRAWING.

What to Check: Restricted or undersized air line.

Corrective Action: Install a larger air line and connection. Refer to air inlet recommendations shown in your pump's SERVICE MANUAL.

What to Check: Check ESADS, the Externally Serviceable Air Distribution System of the pump.

Corrective Action: Disassemble and inspect the main air distribution valve, pilot valve and pilot valve actuators. Refer to the parts drawing and air valve section of the SERVICE MANUAL. Check for clogged discharge or closed valve before reassembly.

What to Check: Rigid pipe connections to pump.

Corrective Action: Install flexible connectors and a Versa-Matic® surge suppressor.

What to Check: Blocked air exhaust muffler.

Corrective Action: Remove muffler screen, clean or de-ice and reinstall. Refer to the Air Exhaust section of your pump SERVICE MANUAL.

What to Check: Pumped fluid in air exhaust muffler.

Corrective Action: Disassemble pump chambers. Inspect for diaphragm rupture or loose diaphragm plate assembly. Refer to the Diaphragm Replacement section of your pump SERVICE MANUAL.

What to Check: Suction side air leakage or air in product.

Corrective Action: Visually inspect all suction side gaskets and pipe connections.

What to Check: Obstructed check valve.

Corrective Action: Disassemble the wet end of the pump and manually dislodge obstruction in the check valve pocket. Refer to the Check Valve section of the pump SERVICE MANUAL for disassembly instructions.

What to Check: Worn or misaligned check valve or check valve seat.

Corrective Action: Inspect check valves and seats for wear and proper seating. Replace if necessary. Refer to Check Valve section of the pump SERVICE MANUAL for disassembly instructions.

What to Check: Blocked suction line.

Corrective Action: Remove or flush obstruction. Check and clear all suction screens and strainers.

What to Check: Blocked discharge line.

Corrective Action: Check for obstruction or closed discharge line valves.

What to Check: Blocked pumping chamber.

Corrective Action: Disassemble and inspect the wetted chambers of the pump. Remove or flush any obstructions.

What to Check: Entrained air or vapor lock in one or both pumping chambers.

Corrective Action: Purge chambers through tapped chamber vent plugs. PURGING THE CHAMBERS OF AIR CAN BE DANGEROUS! Contact the Versa-Matic Technical Services Department before performing this procedure. Any model with top-ported discharge will reduce or eliminate problems with entrained air.

If your pump continues to perform below your expectations, contact your local Versa-Matic Distributor or factory Technical Services Group for a service evaluation.

Warranty: This pump is warranted for a period of five years against defective material and workmanship. Failure to comply with the recommendations stated in this manual voids all factory warranty.



WARNING!

Read these safety warnings and instructions in this manual COMPLETELY, before installation and start-up of the pump. It is the responsibility of the purchaser to retain this manual for reference. Failure to comply with the recommendations stated in this manual will damage the pump, and void factory warranty.



WARNING!

Before doing any maintenance on the pump, be certain all pressure is completely vented from the pump, suction, discharge, piping, and all other openings and connections. Be certain the air supply is locked out or made non-operational, so that it cannot be started while work is being done on the pump. Be certain that approved eye protection and protective clothing are worn all times in the vicinity of the pump. Failure to follow these recommendations may result in serious injury or death.



CAUTION!

Before pump operation, inspect all gasketed fasteners for looseness caused by gasket creep. Re-torque loose fasteners to prevent leakage. Follow recommended torques stated in this manual.



WARNING!

Before maintenance or repair, shut off the compressed air line, bleed the pressure, and disconnect the air line from the pump. The discharge line may be pressurized and must be bled of its pressure.



WARNING!

Take action to prevent static sparking. Fire or explosion can result, especially when handling flammable liquids. The pump, piping, valves, containers or other miscellaneous equipment must be grounded.



IMPORTANT!

This pump is pressurized internally with air pressure during operation. Always make certain that all bolting is in good condition and that all of the correct bolting is reinstalled during assembly.



WARNING!

When used for toxic or aggressive fluids, the pump should always be flushed clean prior to disassembly.



WARNING!

Airborne particles and loud noise hazards. Wear ear and eye protection.



WARNING!

In the event of diaphragm rupture, pumped material may enter the air end of the pump, and be discharged into the atmosphere. If pumping a product which is hazardous or toxic, the air exhaust must be piped to an appropriate area for safe disposition.

RECYCLING

Many components of Versa-Matic Metallic AODD pumps are made of recyclable materials (see chart on page 9 for material specifications). We encourage pump user to recycle worn out parts and pumps whenever possible, after any hazardous pumped fluids are thoroughly flushed.

MATERIAL CODES

The Last 3 Digits of Part Number

000 Assembly, sub-assembly; and some purchased items
010 Cast Iron
012 Powered Metal
015 Ductile Iron
020 Ferritic Malleable Iron
025 Music Wire
080 Carbon Steel, AISI B-1112
100 Alloy 20
110 Alloy Type 316 Stainless Steel
111 Alloy Type 316 Stainless Steel (Electro Polished)
112 Alloy "C" (Hastelloy equivalent)
113 Alloy Type 316 Stainless Steel (Hand Polished)
114 303 Stainless Steel
115 302/304 Stainless Steel
117 440-C Stainless Steel (Martensitic)
120 416 Stainless Steel (Wrought Martensitic)
123 410 Stainless Steel (Wrought Martensitic)
148 Hardcoat Anodized Aluminium
149 2024-T4 Aluminium
150 6061-T6 Aluminium
151 6063-T6 Aluminium
152 2024-T4 Aluminium (2023-T351)
154 Almag 35 Aluminium
155 356-T6 Aluminium
156 356-T6 Aluminium
157 Die Cast Aluminium Alloy #380
158 Aluminium Alloy SR-319
159 Anodized Aluminium
162 Brass, Yellow, Screw Machine Stock
165 Cast Bronze, 85-5-5-5
166 Bronze, SAE 660
170 Bronze, Bearing Type, Oil Impregnated
175 Die Cast Zinc
180 Copper Alloy
305 Carbon Steel, Gray Epoxy Coated
306 Carbon Steel, Black PTFE Coated
307 Aluminium, Gray Epoxy Coated
308 Stainless Steel, Black PTFE Coated
309 Aluminium, Black PTFE Coated
310 Kynar Coated
330 Zinc Plated Steel
331 Chrome Plated Steel

332 Aluminium, Electroless Nickel Plated
333 Carbon Steel, Electroless Nickel Plated
335 Galvanized Steel
336 Zinc Plated Yellow Brass
337 Silver Plated Steel
340 Nickel Plated
342 Filled Nylon
353 Geolast; Color: Black
354 Injection Moulded #203-40 Santoprene- Duro 40D +/-5; Color: RED
355 Thermal Plastic
356 Hytrel
357 Injection Moulded Polyurethane
358 (Urethane Rubber) (Compression Mold)
359 Urethane Rubber
360 Buna-N Rubber. Color coded: RED
361 Buna-N
363 Viton (Fluorel). Color coded: YELLOW
364 EPDM Rubber. Color coded: BLUE
365 Neoprene Rubber. Color coded: GREEN
366 Food Grade Nitrile
368 Food Grade EPDM
370 Butyl Rubber. Color coded: BROWN
371 Philthane (Tuftane)
374 Carboxylated Nitrile
375 Fluorinated Nitrile
378 High Density Polypropylene
405 Cellulose Fibre
408 Cork and Neoprene
425 Compressed Fibre
426 Blue Gard
440 Vegetable Fibre
465 Fibre
500 Delrin 500
501 Delrin 570
502 Conductive Acetal, ESD-800
503 Conductive Acetal, Glass-Filled
505 Acrylic Resin Plastic
506 Delrin 150
520 Injection Moulded PVDF Natural color
540 Nylon
541 Nylon
542 Nylon
544 Nylon Injection Moulded
550 Polyethylene
551 Glass Filled Polypropylene

552 Unfilled Polypropylene
553 Unfilled Polypropylene
555 Polyvinyl Chloride
556 Black Vinyl
570 Rulon II
580 Ryton
590 Valox
591 Nylatron G-S
592 Nylatron NSB
600 PTFE (virgin material) Tetrafluorocarbon (TFE)
601 PTFE (Bronze and moly filled)
602 Filled PTFE
603 Blue Gylon
604 PTFE
607 Envelon
606 PTFE
610 PTFE Encapsulated Silicon
611 PTFE Encapsulated Viton
632 Neoprene/Hytrel
633 Viton/PTFE
634 EPDM/PTFE
635 Neoprene/PTFE
637 PTFE, Viton/PTFE
638 PTFE, Hytrel/PTFE
639 Buna-N/TFE
643 Santoprene®/EPDM
644 Santoprene®/PTFE
656 Santoprene Diaphragm and Check Balls/EPDM Seats

Delrin, Viton and Hytrel are registered trademarks of E.I. DuPont.

Gylon is a registered trademark of Garlock, Inc.

Nylatron is a registered trademark of Polymer Corp.

Santoprene is a registered trademark of Monsanto Corp.

Rulon II is a registered trademark of Dixon Industries Corp.

Hastelloy-C is a registered trademark of Cabot Corp.

Ryton is a registered trademark of Phillips Chemical Co.

Valox is a registered trademark of General Electric Co.

VERSA-MATIC PUMP

INSTALLATION GUIDE Top Discharge Ball Valve Unit

Available from
Versa-Matic Pump

- ① VDA05 Versa-Surge Suppressor
- ② 020-049-000 Filter/Regulator
- ③ 020-049-001 Lubricator
- ④ Air Dryer

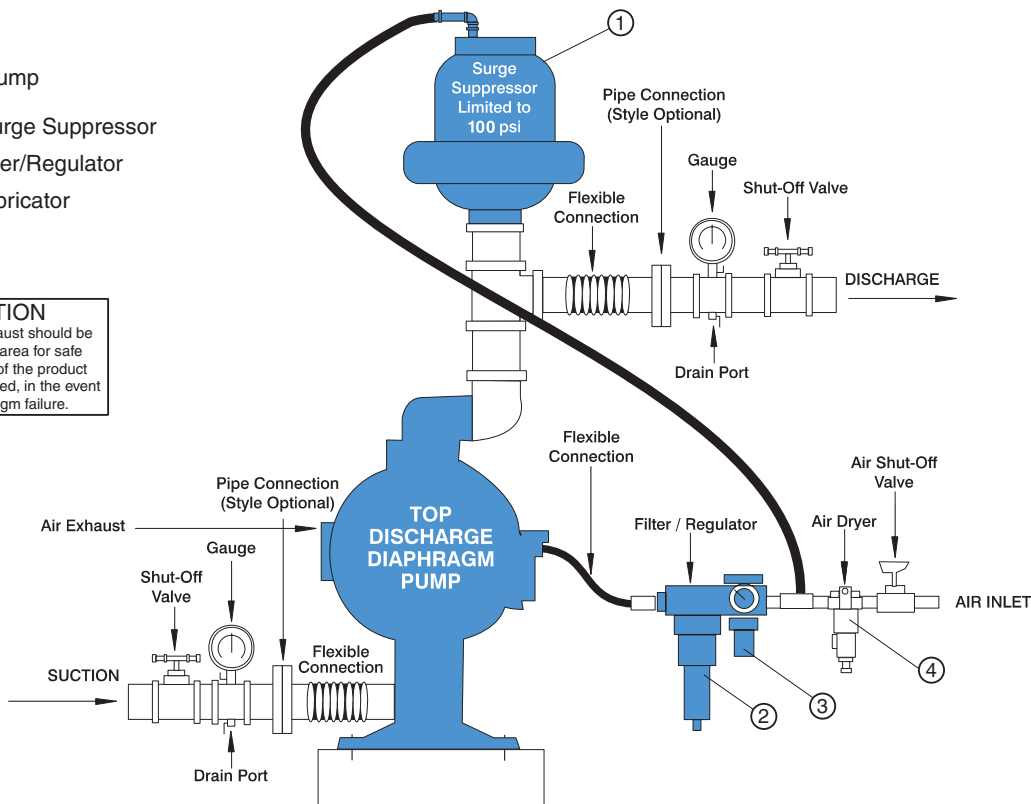
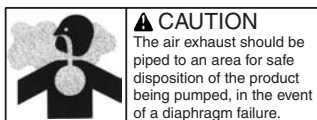

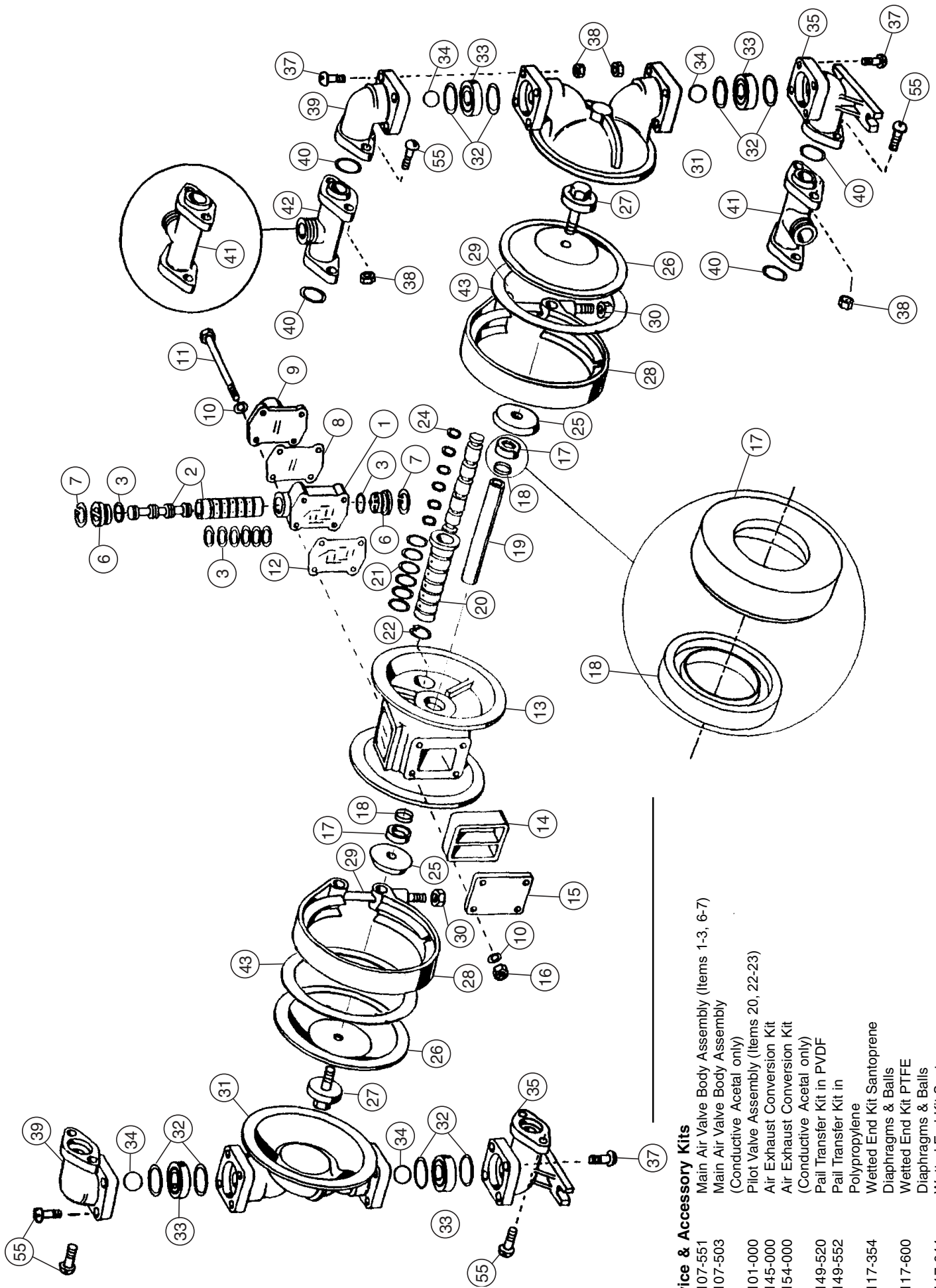

Service & Accessory Kits

- 031-107-551 Main Air Valve Body Assembly (Items 1-3, 6-7)
- 031-107-503 Main Air Valve Body Assembly (Conductive Acetal only)
- 031-101-000 Pilot Valve Assembly (Items 20, 22-23)
- 475-145-000 Air Exhaust Conversion Kit
- 475-154-000 Air Exhaust Conversion Kit (Conductive Acetal only)
- 475-149-520 Pail Transfer Kit in PVDF
- 475-149-552 Pail Transfer Kit in Polypropylene
- 476-117-354 Wetted End Kit Santoprene Diaphragms & Balls
- 476-117-600 Wetted End Kit PTFE Diaphragms & Balls
- 476-117-644 Wetted End Kit Santoprene Diaphragms & Balls
- 476-129-000 Air End Kit

Composite Repair Parts List

ITEM	PART NO.	DESCRIPTION	QTY	ITEM	PART NO.	DESCRIPTION	QTY
1	095-077-551	Body, Main Air Valve	1	27	612-146-520	Plate, Outer Diaphragm	2
	095-077-503	Body, Main Air Valve	1		612-146-502	Plate, Outer Diaphragm	2
2	031-106-000	Sleeve & Spool Set	1	28	200-057-115	Clamp, V-Band	2
3	560-101-360	O-Rings	8	29	100-002-115	T-Bolt	2
6	165-074-551	Cap, End with O-Ring	2	30	545-027-337	Nut, Hex 1/4-28UNF	2
	165-074-503	Cap, End with O-Ring	2	31	196-145-520	Chamber, Outer	2
7	675-051-115	Ring, Retaining	2		196-145-502	Chamber, Outer	2
8	360-085-360	Gasket, Valve Body	1		196-145-552	Chamber, Outer	2
9	165-072-551	Cap, Air Inlet	1	32	720-032-600	Seal, Check Valve	8
	165-072-503	Cap, Air Inlet	1	33	722-073-520	Seat, Check Valve	4
10	901-037-115	Washer, Flat 1/4"	8		722-073-506	Seat, Check Valve	4
11	170-103-115	Capscrew, Hex Head 1/4-20 5" Long	4		722-073-552	Seat, Check Valve	4
12	360-084-360	Gasket, Intermediate Bracket	1	34	050-033-354	Ball, Check	4
13	114-019-551	Intermediate, Bracket	1		050-034-600	Ball, Check	4
	114-019-503	Intermediate, Bracket	1	35	312-095-520	Elbow, Suction	2
14	530-022-550	Muffler	1		312-095-502	Elbow, Suction	2
15	165-073-551	Cap, Air Exhaust	1		312-095-552	Elbow, Suction	2
	165-073-503	Cap, Air Exhaust	1	37	706-023-115	Screw, Machine 10-32UNF x 1" Long	24
16	545-003-115	Nut, Hex 1/4-20UNC	4	38	544-004-115	Nut, Hex Flange 10-32UNF	16
17449-021-551		Insert, Gland	2	39	312-096-520	Elbow, Discharge	2
	449-021-503	Insert, Gland	2		312-096-502	Elbow, Discharge	2
18	720-031-359	Seal, K-R	2		312-096-552	Elbow, Discharge	2
19	685-046-120	Rod, Diaphragm	1	40	720-033-600	Seal, Manifold	4
20	755-038-000	Sleeve, Pilot Valve with O-rings	1	41	518-127-520	Manifold, Horizontal (Optional Discharge)	1/2
21	560-066-360	O-rings	6		518-127-502	Manifold, Horizontal (Optional Discharge)	1/2
22	675-047-115	Ring, Retaining - Pilot Valve Sleeve	1		518-127-552	Manifold, Horizontal (Optional Discharge)	1/2
23	775-038-000	Spool, Pilot Valve with O-rings	1	42	518-128-520	Manifold, Vertical	1
24	560-029-374	O-rings	6		518-128-502	Manifold, Vertical	1
25	612-147-150	Plate, Inner Diaphragm	2		518-128-552	Manifold, Vertical	1
26	286-069-354	Diaphragm	2	43	360-086-360	Gasket, Sealing	2
	286-070-600	Diaphragm	2	54	920-024-000	Ground Strap (Conductive Acetal Units Only)	1
				55	706-023-115	Screw, Machine 10-32 UNF x .88 long	8

Grounding The Pump (for Conductive Acetal Pumps only)

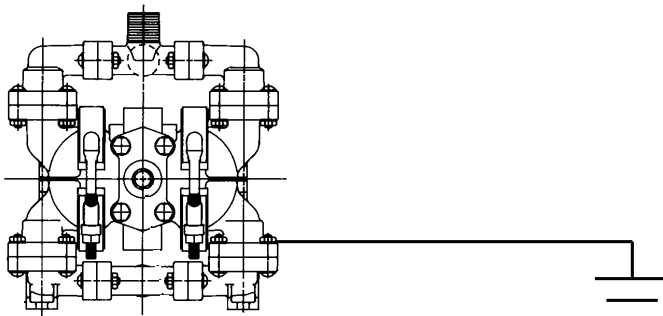
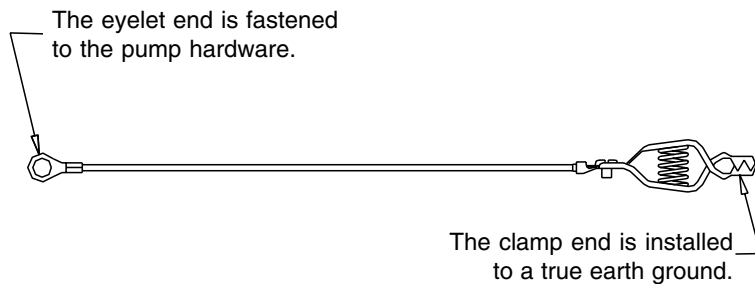

This 8 foot long (244 centimeters) Ground Strap (Item 54) is shipped with the eyelet end fastened to the pump hardware.

To reduce the risk of static electrical sparking, this pump must be grounded. Check the local electrical code for detailed grounding instruction and the type of equipment required.

SOLENOID SHIFTED OPTION DRAWING

SOLENOID SHIFTED AIR VALVE PARTS LIST

(Includes all items used on Composite Repair Parts List except as shown)

ITEM	PART NUMBER	DESCRIPTION	QTY
22	675-047-115	Ring, Retaining - Pilot Plug Sleeve	2
44	755-037-000	Pilot Plug Sleeve with O-rings	1
45	360-106-360	Gasket, Intermediate Bracket	1
46	241-001-000	Connector, conduit	1
47	893-095-000	Solenoid Valve, NEMA 4	1
48	219-001-000	Solenoid Coil, 24 VDC	1
	219-004-000	Solenoid Coil, 24 VAC/12 VDC	1
	219-002-000	Solenoid Coil, 120 VAC	1
	219-003-000	Solenoid Coil, 240 VAC	1
49	866-068-000	Tube Fitting	1
50	538-083-555	Nipple	1
51	835-009-555	Tee, Pipe	1
52	860-062-540	Tubing	1
53	866-069-000	Tube Fitting	1

ASSEMBLY INSTRUCTIONS: MUST BE PERFORMED PRIOR TO START-UP.

The tee (item 51), nipple (item 50), fitting (item 53) and tubing (item 52) have been pre-assembled at the factory. Thread this assembly into the air inlet cap (item 9). Be careful not to over tighten. Push the free end of the tubing into the fitting (item 49) which is attached to the valve.

For Explosion Proof Solenoid Valve

(Connector not required for explosion proof coil; coil is integral with valve)

47	893-096-001	Solenoid Valve, NEMA 7/9, 24VDC	1
	893-096-002	Solenoid Valve, NEMA 7/9, 24VAC/12VDC	1
	893-096-003	Solenoid Valve, NEMA 7/9, 120VAC	1
	893-096-004	Solenoid Valve, NEMA 7/9, 240VAC	1

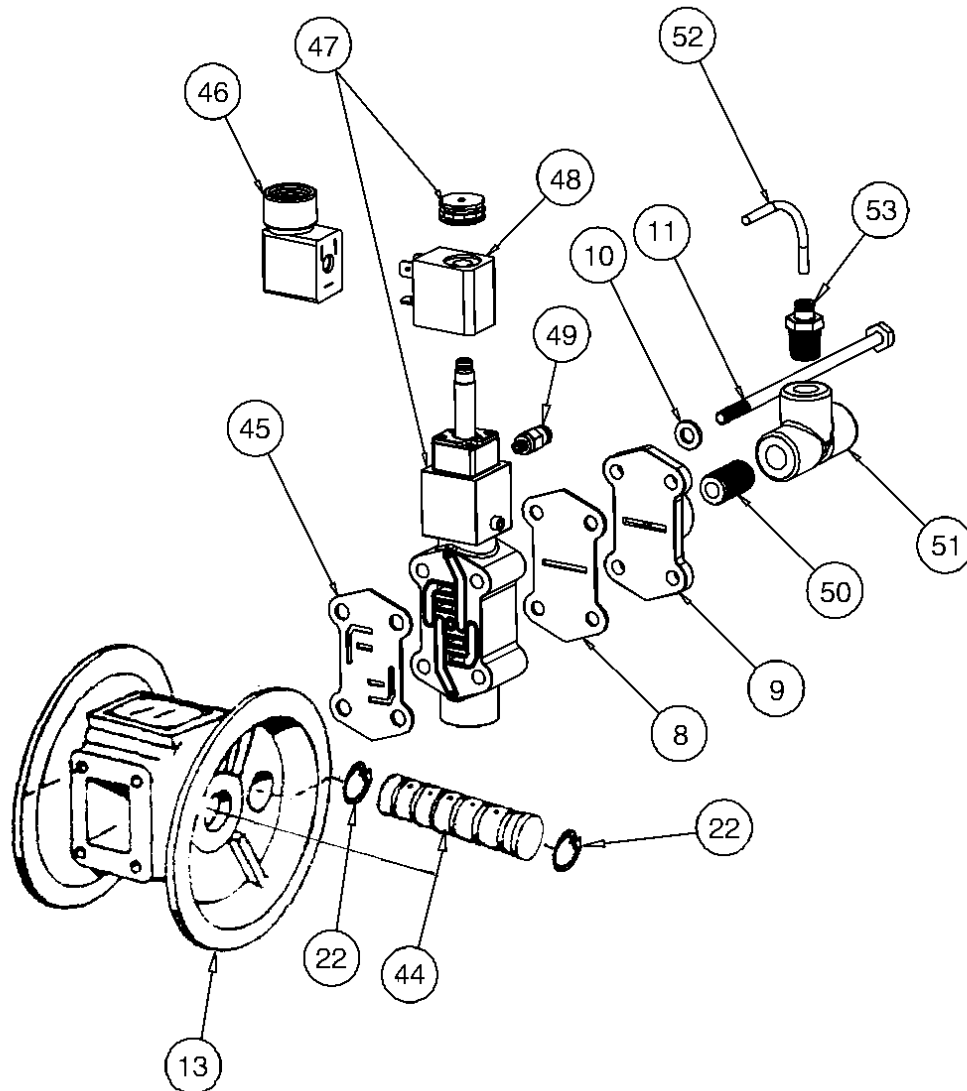

SOLENOID SHIFTED AIR DISTRIBUTION VALVE OPTION

Versa-Matic's solenoid shifted, air distribution valve option utilizes electrical signals to precisely control your pump's speed. The solenoid coil is connected to the Versa-Matic Solenoid Rate Controller/Batch Control, or a customer - supplied control. Compressed air provides the pumping power, while electrical signals control pump speed (pumping rate).

OPERATION

The Solenoid Shifted Versa-Matic pump has a solenoid operated, air distribution valve in place of the standard Versa-Matic's pilot operated, air distribution valve. Where a pilot valve is normally utilized to cycle the pump's air distribution valve, an electric solenoid is utilized. As the solenoid is powered, one of the pump's air chambers is pressurized while the other chamber is exhausted. When electric power is turned off, the solenoid shifts and the pressurized chamber is exhausted while the other chamber is pressurized. By alternately applying and removing power to the solenoid, the pump cycles much like a standard pump, with one exception. This option provides a way to precisely control and monitor pump speed.

BEFORE INSTALLATION

Before wiring the solenoid, make certain it is compatible with your system voltage.

