

2" Ultra-Matic™ Bolted Plastic Pumps

Side and Optional Adjustable Center Porting Models

U2

- ▶ Polypropylene
- ▶ Kynar

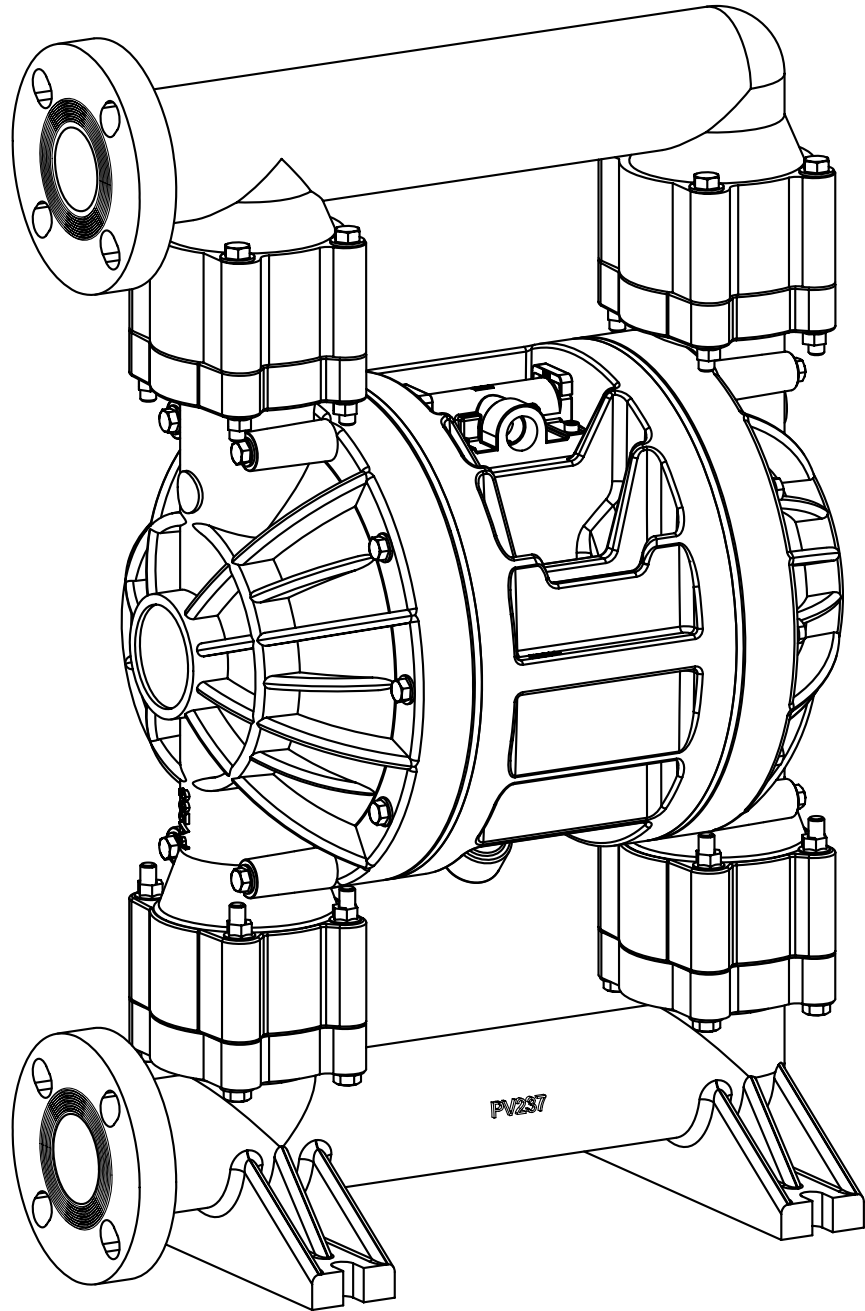
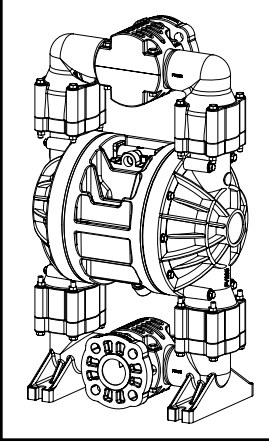

SAFETY WARNINGS

Read these instructions completely before installation and start-up. It is the responsibility of the purchaser to retain this manual for reference. Failure to comply with the recommendations stated in this manual could result in death, serious bodily injury and/or property damage including damage to the pump and/or voiding the factory warranty.

Correct pump selection is crucial to the pump operation. Please assure pressure, temperature and chemical compatibility before installation. Please consult Versa-Matic Pump, Engineering Specifications, Chemical Compatibility Chart, or your distributor if in doubt about any application.

Operating Limitations for Various Elastomers

Neoprene	0°F (-18°C) to 200°F (93°C)
Buna-N	10°F (-12°C) to 180°F (82°C)
Nordel	-60°F (-51°C) to 280°F (138°C)
FKM Fluorocarbon	-40°F (-40°C) to 350°F (176°C)
PTFE	40°F (4°C) to 220°F (105°C)
Polyurethane	10°F (-12°C) to 170°F (77°C)
XL TPE	-20°F (-29°C) to 300°F (149°C)
FDA Hytrel	-20°F (-29°C) to 220°F (104°C)

Operating Limitations for Plastic Pumps

Kynar (PVDF)	10°F (-12°C) to 225°F (107°C)
Polypropylene	32°F (0°C) to 175°F (79°C)

Maximum temperature limits are based upon mechanical stress only. Certain chemicals and environment conditions significantly reduce maximum safe temperature limits.

Before pump operation, inspect all gasketed fasteners for looseness caused by gasket creep. Re-torque all loose fasteners to prevent leakage. Follow recommended torques

stated in this manual. Failure of the sealing components creates the possibility of jetting or forceful discharge of pumped material at a potentially harmful velocity.

Be certain that approved eye protection and protective clothing are always worn during installation, service, maintenance or when in the vicinity of the pump. Failure to follow these recommendations may result in serious injury or death.

Never allow the piping system to be supported by the pump manifolds or valve housing. The manifolds and valve housing are not designed to support any structural weight and failure of the pump may result.

Take action to prevent static sparking. Fire or explosion can result, especially when handling flammable liquids. The pump, piping, valves, containers, or other miscellaneous equipment must be grounded.

Noise levels can exceed 85 dBA. Take precautions to prevent personal injury due to excessive pump noise.

Do not exceed pump maximum operating pressure (found on label and/or operating manual.)

Before doing any maintenance or repair on this pump, be certain all pressure is completely vented for the pump, suction, discharge, piping, and all other openings.

In the event of a diaphragm rupture, pumped material may enter the air end of the pump and be discharged into the atmosphere. If pumping a product that is hazardous or toxic, the air exhaust must be piped to an appropriate area for safe disposition.

U2P SPECIFICATIONS AND PERFORMANCE

Versa-Matic Ultra-Matic Model U2 2" Bolted Plastic Pumps

Flow Rate

Adjustable to 0-183 gpm (693 lpm)

Port Size

Suction 2" ANSI/DIN#50 Flange

Discharge 2" ANSI/DIN#50 Flange

Air Inlet 0.50" Female NPT

Air Exhaust 0.75" Female NPT

Suction Lift

Rubber 20' (6.1 m) Dry

PTFE 10' (3.0 m) Dry

Max. Particle Size (Dia.) . . . 0.25" (6 mm)

dB(A) Reading 75 dB(A)

Shipping Weight

Poly — End Port 67 lbs (30 kg)

Poly — Center Port 72 lbs (33 kg)

Kynar — End Port 93 lbs (42 kg)

Kynar — Center Port 98 lbs (44 kg)

Caution: do not exceed 100 psig (6.9 bar) liquid or air supply pressure.

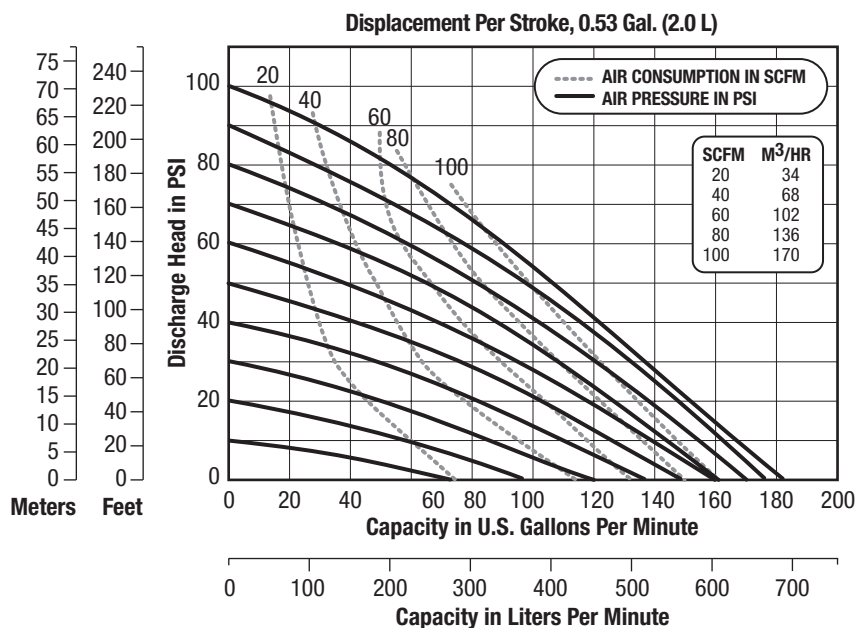

U2P SPECIFICATIONS AND PERFORMANCE

U2 2" Bolted Plastic Pump with End Ports

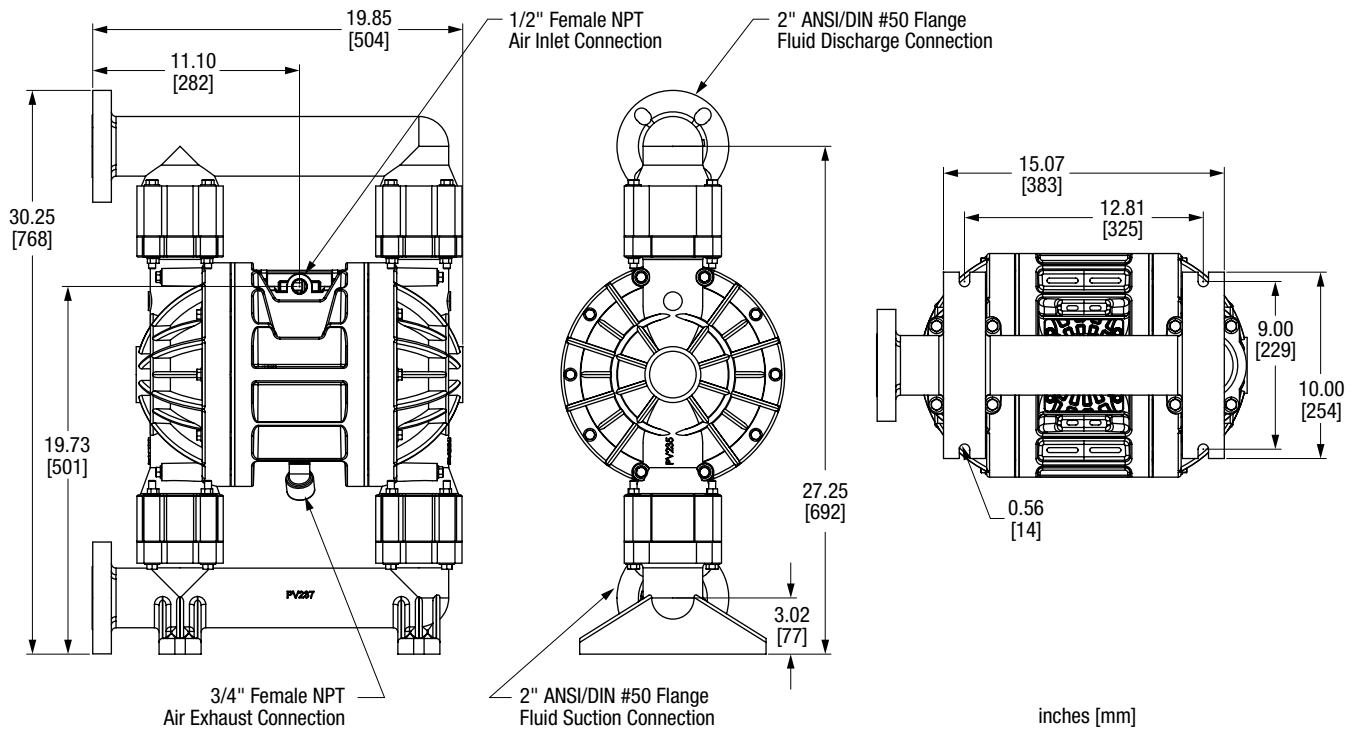

U2 2" Bolted Plastic Pump with Center Ports

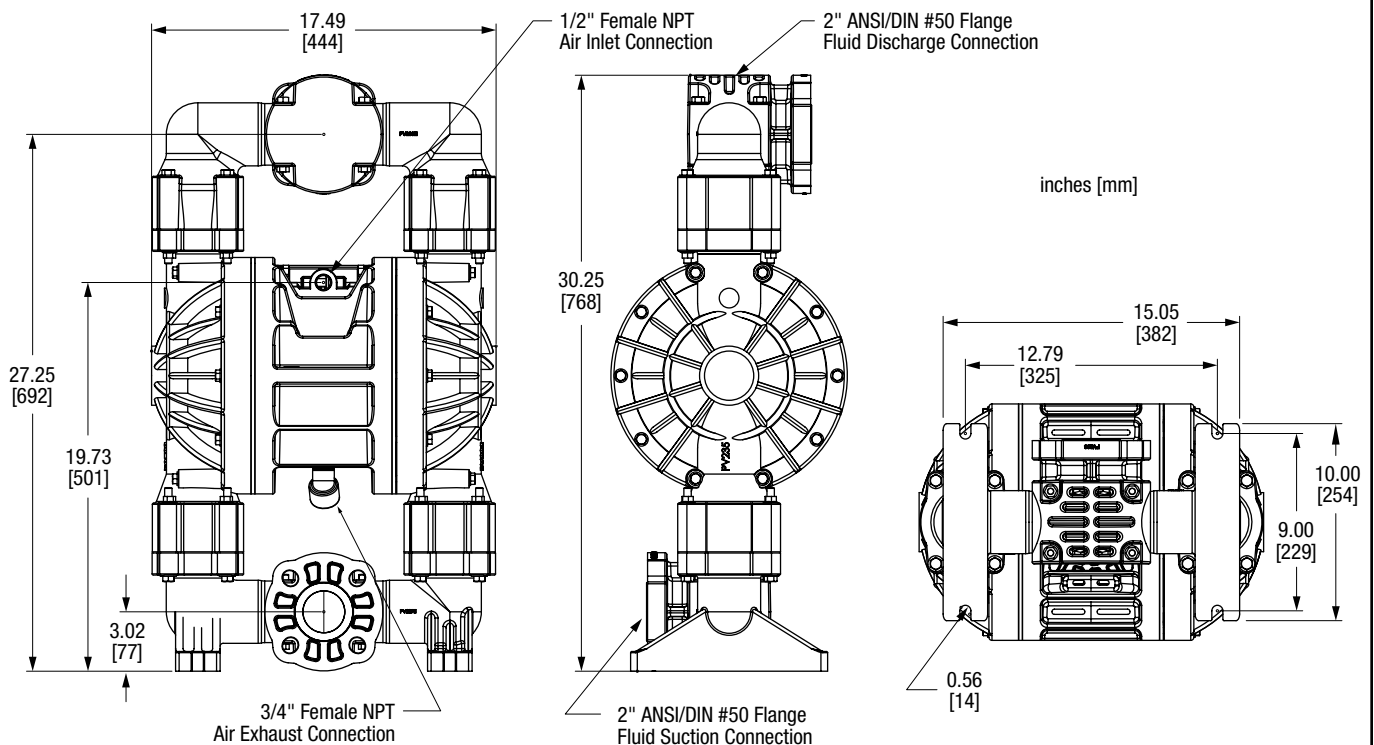

INSTALLATION, OPERATION AND MAINTENANCE

Installation

The pump should be mounted in a vertical position. In permanent installations, the pump should be attached to plant piping using a flexible coupling on both the intake and discharge connections to reduce vibration to the pump and piping. To further reduce vibration, a surge suppressor next to the pump may be used.

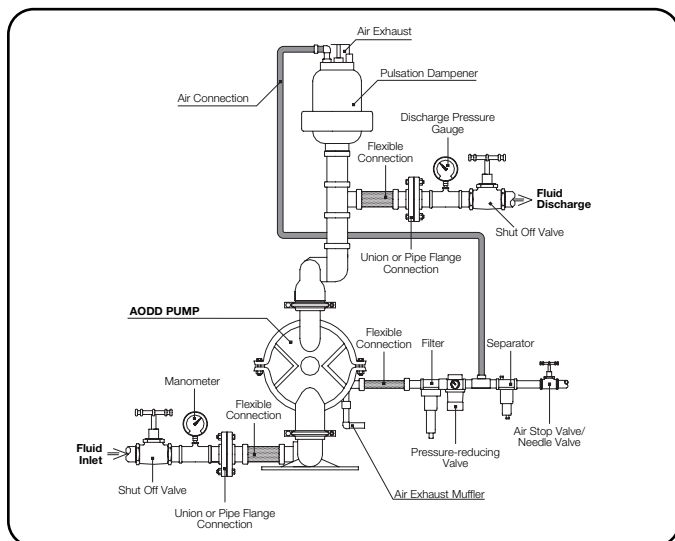

Suction pipe size should be at least the same diameter as the inlet connection size, even larger if highly viscous fluid is to be pumped. If suction hose is used, it must be of a non-collapsible reinforced type. Discharge piping should be of at least the same diameter as the discharge connection. It is critical,

especially on the suction side of the pump, that all fittings and connections are air tight or pumping efficiency will be reduced and priming will be difficult.

Make certain the air supply line and connections and compressor are capable of supplying the required pressure and volume of air to operate the pump at the desired flow rate. The quality of the compressed air source should be considered. Air that is contaminated with moisture and dirt may result in erratic pump performance and increased maintenance cost as well as frequent process “down time” when the pump fails to operate properly.

Pump Operation

The pump is powered by compressed air. Compressed air is directed to the pump air chamber by the main air valve. The compressed air is separated from the fluid by a membrane called a diaphragm. The diaphragm in turn applies pressure on the fluid and forces it out of the pump discharge. While this is occurring, the opposite air chamber is de-pressurized and exhausted to atmosphere and fluid is drawn into the pump suction. The cycle again repeats, thus creating a constant reciprocating action which maintains flow through the pump. The flow is always in through the bottom suction connection and out through the top discharge connection. Since the air pressure acts directly on the diaphragms, the pressure applied to the fluid roughly approximates the air supply pressure supplied to the main air valve.

Recommended Piping Connections

Pump Size	Minimum Air Line Size	Minimum Suction Line Size
1/2"	1/2"	1/2"
1"	1/2"	1"
1-1/2"	1/2"	1-1/2"
2"	1/2"	2"
3"	3/4"	3"

U2 2" Bolted Plastic Pump Torque Settings

Manifold Bolts	50 in-lbs (5.6 N-m)
Water Chamber Bolts	100 in-lbs (11.3 N-m)
Diaphragm Plates — Rubber	40 ft-lbs (54 N-m)
Diaphragm Plates — PTFE	50 ft-lbs (68 N-m)
Air Valve Cap Screws	25 in-lbs (2.8 N-m)
Muffler Plate Cap Screws	30 in-lbs (3.4 N-m)

Elastomer Suffix Codes

Suffix Code	Material
A	Acetal
BN	Buna-N, Nitrile
N	Neoprene
ND	Nordel, EPDM
TF	PTFE
FG	Hytrel
XL	XL, Santoprene
VT	FKM Fluorocarbon
TX	Bonded PTFE

U2P PARTS LIST

AIR VALVE ASSEMBLY					
Item	Description	Qty	Standard: Polypropylene	Option 1: Conductive Polypropylene (ATEX)	
	Air Valve Assembly (Includes items 1-10)	1	E200	E200	E200-ATEX
1	Valve Body	1	E200A	E200A	E200A-ATEX
2	Valve Spool	1	E200B ASY (Includes U-Cups)	E200B ASY (Includes U-Cups)	E200B ASY (Includes U-Cups)
3	Valve Spool U-Cup	2	P98-104A	P98-104A	P98-104A
4	End Cap	2	E500D ASY (Includes O-Rings)	E500D ASY (Includes O-Rings)	E500D-ATEX ASY (Includes O-Rings)
5	End Cap O-Ring	2	E500E	E500E	E500E
6	End Cap Staple	2	E500F	E500F	E500F
7	Staple Retainer	2	E200L	E200L	E200L
8	Air Diverter	1	E200G	E200G	E200G
9	Valve Insert	1	E200H	E200H	E200H
10	Valve Gasket	1	E200J	E200J	E200J
11	Valve Cap Screw	4	P24-209	P24-209	P24-209
AIR END ASSEMBLY					
Item	Description	Qty	Standard: Polypropylene	Option 1: Conductive Polypropylene (ATEX)	
12	Center Section	1	E201A	E201A	E201A-ATEX
17	Bushing	2	E201MB	E201MB	E201MB
18	Pilot Shaft	1	E203A	E203A	E203A
19	Pilot Shaft Spacer	5	P24-106P	P24-106P	P24-106P
20	Pilot Shaft O-Ring	6	P24-107	P24-107	P24-107
21	Stop Nut	2	P24-108	P24-108	P24-108
22	Shaft Retainer – Left	1	E201B-L ASY (Includes O-Rings)	E201B-L ASY (Includes O-Rings)	E201B-L ASY (Includes O-Rings)
23	Shaft Retainer – Right (not shown)	1	E201B-R ASY (Includes O-Rings)	E201B-R ASY (Includes O-Rings)	E201B-R ASY (Includes O-Rings)
24	Shaft Retainer O-Ring	4	E201B-5	E201B-5	E201B-5
25	Shaft Retainer Screw	8	10-050	10-050	10-050
26	Exhaust Valve	2	E201D ASY	E201D ASY	E201D ASY
27	Exhaust Sleeve O-Ring	2	E201M-1	E201M-1	E201M-1
28	Retainer Plate seat	2	E201B-3	E201B-3	E201B-3
29	Muffler Plate	1	E201H	E201H	E201H-ATEX
30	Muffler Plate Gasket	1	E200J-1	E200J-1	E200J-1
31	Muffler Plate Cap Screw	4	E201G	E201G	E201G
32	Muffler Elbow	1	PE201N	PE201N	PE201N
33	Muffler	1	V20AEM	V20AEM	V20AEM
DIAPHRAGM ASSEMBLY					
Item	Description	Qty	DOME	Teflon Bonded	Teflon 2-Piece
35	Main Shaft	1	P24-103	P24-102	P24-102
37	Inner Diaphragm Plate	2	V226B SV226B V226BTC V226BN	V221T SV221TI V221TITC V221TINP	V221TI SV221TI V221TITC V221TINP
38	Outer Diaphragm Plate	2	PV226B KV226B	PV221TO KV221TO	PV221TO KV221TO
40	Diaphragm	2	V227BN V227N V227ND V227VT V227XL V227FG V227FG	V227TX	V227TF
41	Back-up Diaphragm	2	N/A	N/A	V227TFB
WET END ASSEMBLY					
Item	Description	Qty	Standard: Polypropylene	Option 1: Kynar	Option 2: Conductive Polypropylene
44	Water Chamber	2	PV235	KV235	PV235-ATEX
45	Water Chamber Bolt (long)	8	E235A	E235A	E235A
46	Water Chamber Bolt (short)	12	SV186A	SV186A	SV186A
47	Water Chamber Washer	20	SV250C	SV250C	SV250C
50	Valve Seat	4	PV240	KV240	PV240
51	Valve Seat O-Ring	8	V258BN V258ND V258TES V258TEV V258VT V258XL		
52	Valve Ball	4	V241BN V241N V241ND V241P V241TF V241XL V241FG V241VT		
Port Option 1: Side Port					
60	Discharge Manifold	1	PV236	KV236	PV236-ATEX
61	Inlet Manifold	1	PV237	KV237	PV237-ATEX
63	Manifold Bolt	16	SV251A	SV251A	SV251A
64	Manifold Washer	16	SV302GA	SV302GA	SV302GA
65	Manifold Nut	16	SV251B	SV251B	SV251B
Port Option 2: Center Port					
53	Manifold Discharge Elbow	2	PV236E	KV236E	PV236E-ATEX
54	Manifold Inlet Elbow	2	PV237E	KV237E	PV237E-ATEX
55	Manifold Tee	2	PV288	KV288	PV288-ATEX
56	Manifold Tee O-Ring	4	V288BN V288TES V288XL	V288BN V288TES V288XL	V288BN V288TES V288XL
57	Manifold Tee Bolt	8	SV288B	SV288B	SV288B
58	Manifold Tee Washer	8	SV302GA	SV302GA	SV302GA
59	Manifold Tee Nut	8	SV251B	SV251B	SV251B
63	Manifold Bolt	16	SV251A	SV251A	SV251A
64	Manifold Washer	16	SV302GA	SV302GA	SV302GA
65	Manifold Nut	16	SV251B	SV251B	SV251B

U2P EXPLODED VIEWS

Standard End Port with Dome Diaphragms

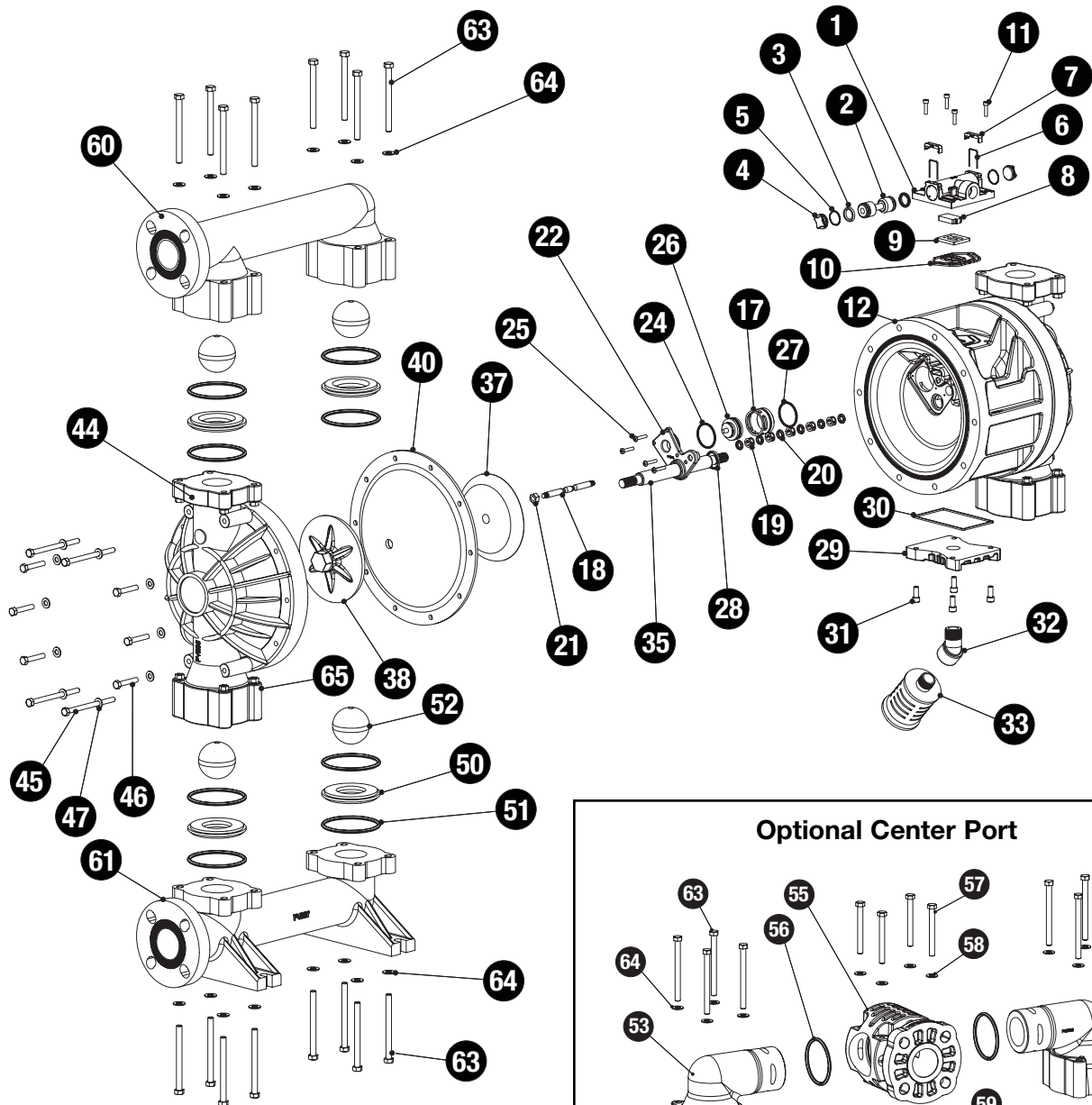

Optional Center Port

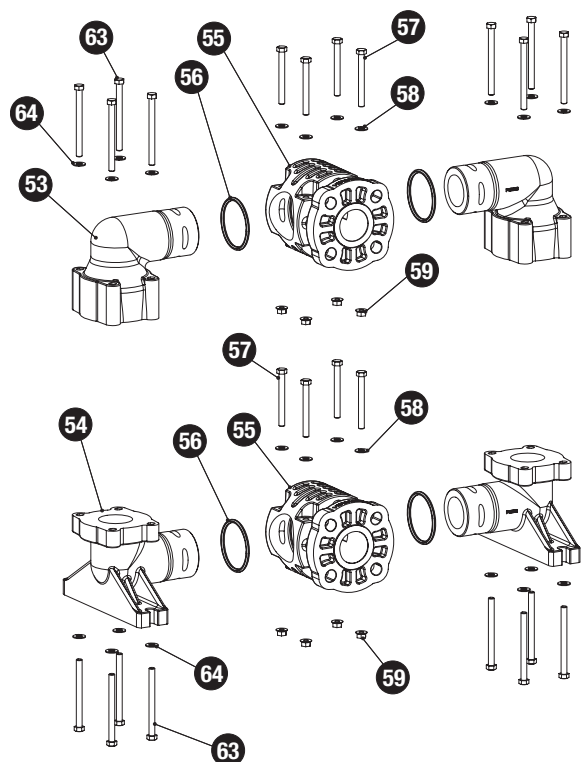

PTFE Diaphragms

