

2" Ultra-Matic™ Bolted Aluminum Pump

U2

► Aluminum

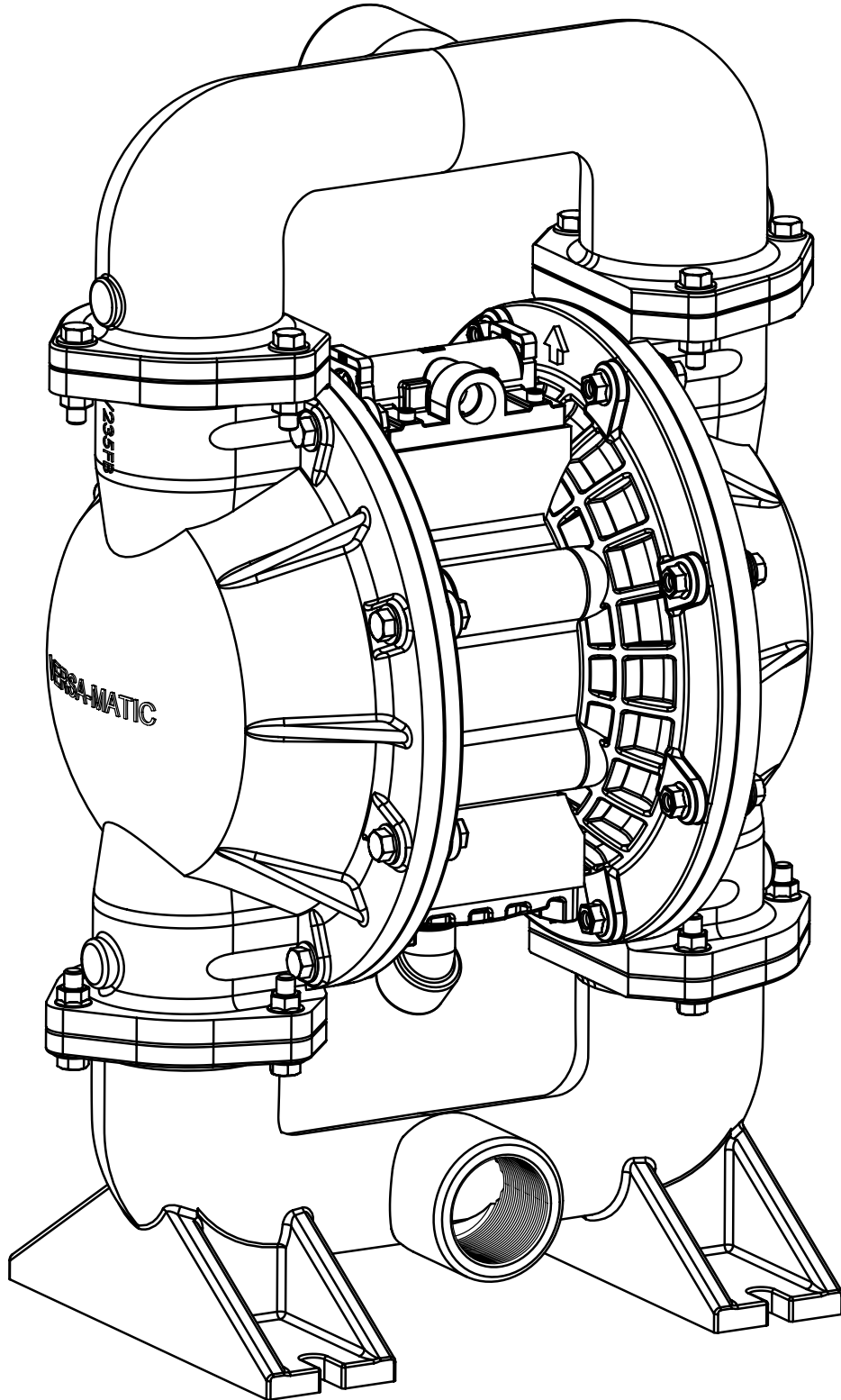

SAFETY WARNINGS

Read these instructions completely before installation and start-up. It is the responsibility of the purchaser to retain this manual for reference. Failure to comply with the recommendations stated in this manual could result in death, serious bodily injury and/or property damage including damage to the pump and/or voiding the factory warranty.

Correct pump selection is crucial to the pump operation. Please assure pressure, temperature and chemical compatibility before installation. Please consult Versa-Matic Pump, Engineering Specifications, Chemical Compatibility Chart, or your distributor if in doubt about any application.

Operating Limitations for Various Elastomers

Neoprene	0°F (-18°C) to 200°F (93°C)
Buna-N	10°F (-12°C) to 180°F (82°C)
Nordel	-60°F (-51°C) to 280°F (138°C)
FKM Fluorocarbon	-40°F (-40°C) to 350°F (176°C)
PTFE	40°F (4°C) to 220°F (105°C)
Polyurethane	10°F (-12°C) to 170°F (77°C)
XL TPE	-20°F (-29°C) to 300°F (149°C)
FDA Hytrel	-20°F (-29°C) to 220°F (104°C)

Operating Limitations for Plastic Pumps

Kynar (PVDF)	10°F (-12°C) to 225°F (107°C)
Polypropylene	32°F (0°C) to 175°F (79°C)

Maximum temperature limits are based upon mechanical stress only. Certain chemicals and environment conditions significantly reduce maximum safe temperature limits.

Before pump operation, inspect all gasketed fasteners for looseness caused by gasket creep. Re-torque all loose fasteners to prevent leakage. Follow recommended torques

stated in this manual. Failure of the sealing components creates the possibility of jetting or forceful discharge of pumped material at a potentially harmful velocity.

Be certain that approved eye protection and protective clothing are always worn during installation, service, maintenance or when in the vicinity of the pump. Failure to follow these recommendations may result in serious injury or death.

Never allow the piping system to be supported by the pump manifolds or valve housing. The manifolds and valve housing are not designed to support any structural weight and failure of the pump may result.

Take action to prevent static sparking. Fire or explosion can result, especially when handling flammable liquids. The pump, piping, valves, containers, or other miscellaneous equipment must be grounded.

Noise levels can exceed 85 dBA. Take precautions to prevent personal injury due to excessive pump noise.

Do not exceed pump maximum operating pressure (found on label and/or operating manual.)

Before doing any maintenance or repair on this pump, be certain all pressure is completely vented for the pump, suction, discharge, piping, and all other openings.

In the event of a diaphragm rupture, pumped material may enter the air end of the pump and be discharged into the atmosphere. If pumping a product that is hazardous or toxic, the air exhaust must be piped to an appropriate area for safe disposition.

U2ALB SPECIFICATIONS AND PERFORMANCE

Versa-Matic Ultra-Matic Model U2 2" Bolted Aluminum Pump

Flow Rate

Adjustable to 0-180 gpm (681 lpm)

Port Size

Suction 2" Female NPT (BSP)

Discharge 2" Female NPT (BSP)

Air Inlet 0.50" Female NPT

Air Exhaust 0.75" Female NPT

Suction Lift

Rubber 20' (6.1 m) Dry

PTFE 10' (3.0 m) Dry

Max. Particle Size (Dia.) . . 0.44" (11 mm)

dB(A) Reading 75 dB(A)

Shipping Weight

Aluminum 71 lbs (32 kg)

**Caution: do not exceed 125 psig
(8.5 bar) liquid or air supply pressure.**

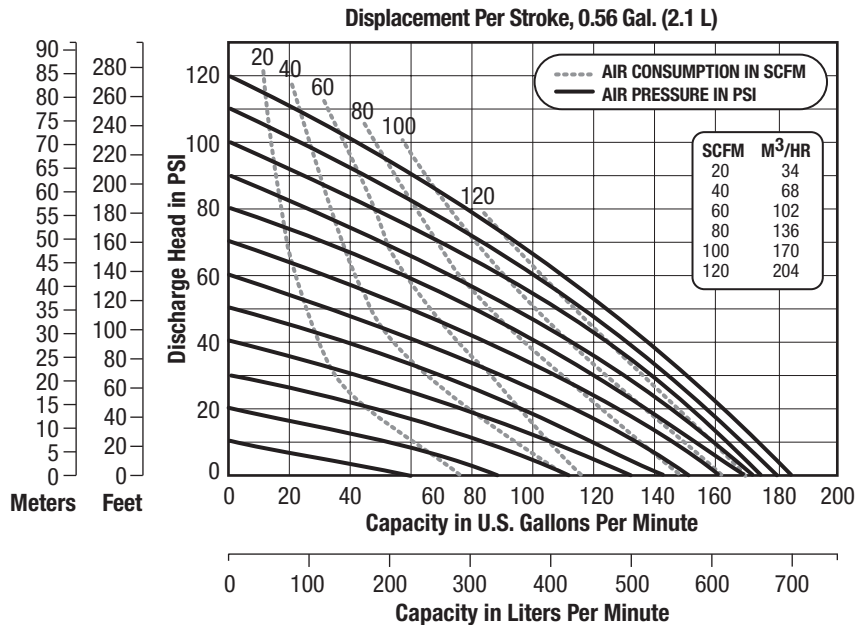

U2ALB 2" Bolted Aluminum Pump

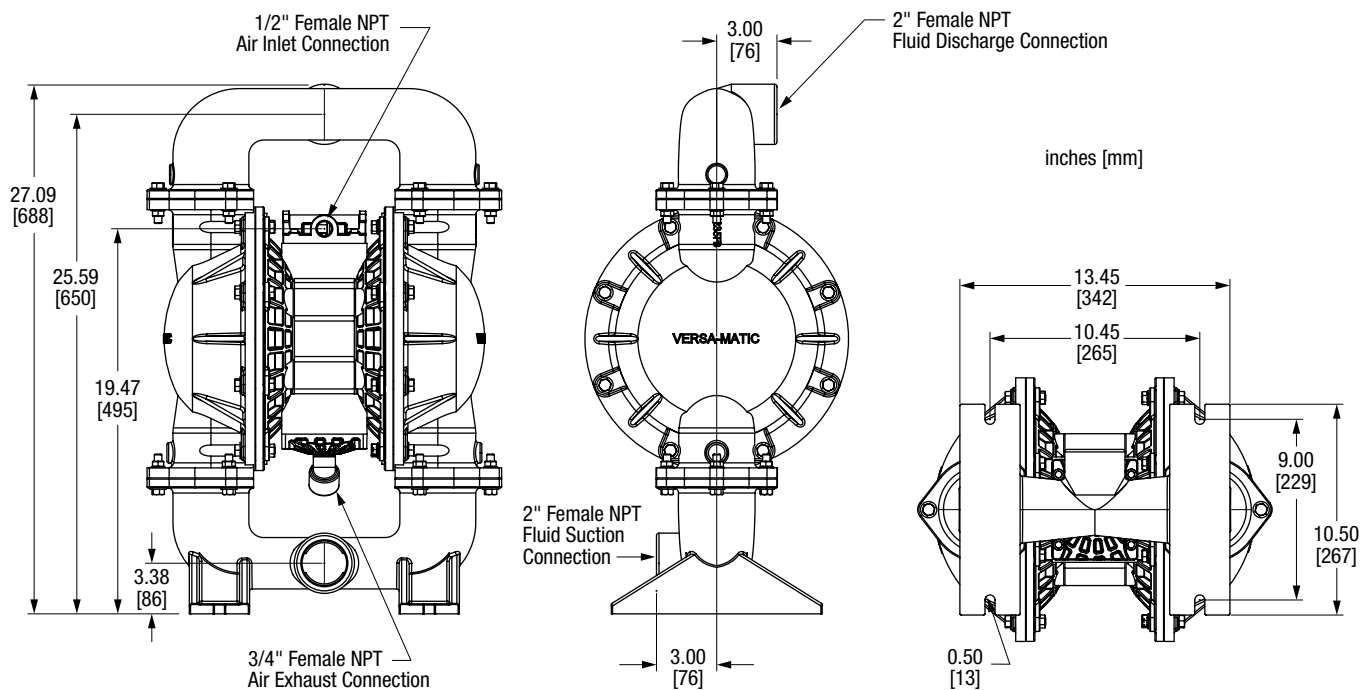

INSTALLATION, OPERATION AND MAINTENANCE

Installation

The pump should be mounted in a vertical position. In permanent installations, the pump should be attached to plant piping using a flexible coupling on both the intake and discharge connections to reduce vibration to the pump and piping. To further reduce vibration, a surge suppressor next to the pump may be used.

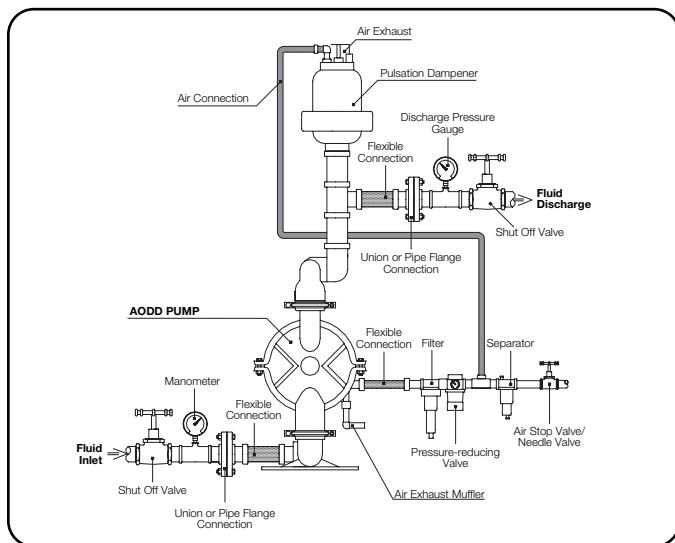

Suction pipe size should be at least the same diameter as the inlet connection size, even larger if highly viscous fluid is to be pumped. If suction hose is used, it must be of a non-collapsible reinforced type. Discharge piping should be of at least the same diameter as the discharge connection. It is critical,

especially on the suction side of the pump, that all fittings and connections are air tight or pumping efficiency will be reduced and priming will be difficult.

Make certain the air supply line and connections and compressor are capable of supplying the required pressure and volume of air to operate the pump at the desired flow rate. The quality of the compressed air source should be considered. Air that is contaminated with moisture and dirt may result in erratic pump performance and increased maintenance cost as well as frequent process “down time” when the pump fails to operate properly.

Pump Operation

The pump is powered by compressed air. Compressed air is directed to the pump air chamber by the main air valve. The compressed air is separated from the fluid by a membrane called a diaphragm. The diaphragm in turn applies pressure on the fluid and forces it out of the pump discharge. While this is occurring, the opposite air chamber is de-pressurized and exhausted to atmosphere and fluid is drawn into the pump suction. The cycle again repeats, thus creating a constant reciprocating action which maintains flow through the pump. The flow is always in through the bottom suction connection and out through the top discharge connection. Since the air pressure acts directly on the diaphragms, the pressure applied to the fluid roughly approximates the air supply pressure supplied to the main air valve.

Recommended Piping Connections

Pump Size	Minimum Air Line Size	Minimum Suction Line Size
1/2"	1/2"	1/2"
1"	1/2"	1"
1-1/2"	1/2"	1-1/2"
2"	1/2"	2"
3"	3/4"	3"

U2 2" Aluminum Pump Torque Settings

Manifold Bolts	35 ft-lbs (47 N-m)
Water Chamber Bolts	35 ft-lbs (47 N-m)
Diaphragm Plates — Rubber	64 ft-lbs (88 N-m)
Diaphragm Plates — PTFE	65 ft-lbs (88 N-m)
Air Valve Cap Screws	25 in-lbs (2.8 N-m)
Muffler Plate Cap Screws	30 in-lbs (3.4 N-m)
Air Chamber Bolts	20 ft-lbs (27 N-m)

Elastomer Suffix Codes

Suffix Code	Material
A	Acetal
BN	Buna-N, Nitrile
N	Neoprene
ND	Nordel, EPDM
TF	PTFE
FG	Hytrel
XL	XL, Santoprene
VT	FKM Fluorocarbon
TX	Bonded PTFE

U2ALB PARTS LIST

AIR VALVE ASSEMBLY				
Item	Description	Qty	Standard: Polypropylene	Option 1: Conductive Polypropylene (ATEX)
	Air Valve Assembly (Includes Items 1-10)		E200	E200-ATEX
1	Valve Body	1	E20A	E200A-ATEX
2	Valve Spool	1	E200B ASY (Includes U-Cups)	E200B ASY (Includes U-Cups)
3	Valve Spool U-Cup	2	P98-104A	P98-104A
4	End Cap	2	E500D ASY (Includes O-Rings)	E500D-ATEX ASY (Includes O-Rings)
5	End Cap O-Ring	2	E500E	E500E
6	End Cap Staple	2	E500F	E500F
7	Staple Retainer	2	E200L	E200L
8	Air Diverter	1	E200G	E200G
9	Valve Insert	1	E200H	E200H
10	Valve Gasket	1	E200J	E200J
11	Valve Cap Screw	4	P24-209	P24-209

AIR END ASSEMBLY				
Item	Description	Qty	Standard: Polypropylene	Option 1: Conductive Polypropylene (ATEX)
12	Center Section	1	E210	E210-ATEX
13	Air Chamber Gasket	2	E212	E212
14	Air Chamber	2	E211A	E211A
15	Air Chamber Bolt	12	V302G	V302G
15A	Air Chamber Nut (not shown)	2	V354C	V354C
16	Air Chamber Washer	12	V302GA	V302GA
17	Bushing	2	E201MB	E201MB
18	Pilot Shaft	1	E203A	E203A
19	Pilot Shaft Spacer	5	P24-106P	P24-106P
20	Pilot Shaft O-Ring	6	P24-107	P24-107
21	Stop Nut	2	P24-108	P24-108
22	Shaft Retainer – Left	1	E201B-L ASY (Includes O-Rings)	E201B-L ASY (Includes O-Rings)
23	Shaft Retainer – Right (not shown)	1	E201B-R ASY (Includes O-Rings)	E201B-R ASY (Includes O-Rings)
24	Shaft Retainer O-Ring	4	E201B-5	E201B-5
25	Shaft Retainer Screw	8	10-050	10-050
26	Exhaust Valve	2	E210D ASY	E210D ASY
27	Exhaust Sleeve O-Ring	2	E201M-1	E201M-1
28	Retainer Plate seat	2	E201B-3	E201B-3
29	Muffler Plate	1	E201H	E201H-ATEX
30	Muffler Plate Gasket	1	E200J-1	E200J-1
31	Muffler Plate Cap Screw	4	E201G	E201G
32	Muffler Elbow	1	PE201N	PE201N
33	Muffler	1	V20AEM	V20AEM

DIAPHRAGM ASSEMBLY						
Item	Description	Qty	Rugged	Dome	PTFE Bonded	PTFE 2-Piece
35	Main Shaft	1	P24-103	P24-103	P24-102	P24-102
36	Diaphragm Shaft Stud	2	N/A	N/A	V221F	V221F
37	Inner Diaphragm Plate	2	V221B	V226B	V221TI	V221TI
38	Outer Diaphragm Plate	2	VB221	VB226	V221TO	V221TO
39	Diaphragm O-Ring	2	V221D	N/A	N/A	N/A
40	Diaphragm	2	V224BN V224N V224ND V224VT V224XL V224FG	V225BN V225N V225ND V225VT V225XL V225FG	V224TX	V224TF
41	Back-up Diaphragm	2	N/A	N/A	N/A	V224TFB

WET END ASSEMBLY				
Item	Description	Qty	Standard: Aluminum	
44	Water Chamber	2	V235FB	
45	Water Chamber Bolt	16	V251D	
47	Water Chamber Washer	16	V302GA	
48	Water Chamber Nut	16	V354C	
50	Valve Seat	4	V240BN V240N V240ND V240FG V240TF V240VT V240XL	
52	Valve Ball	4	V241BN V241N V241ND V241P V241TF V241XL V241FG V241VT V240SS	
60	Discharge Manifold	1	V236FB	
61	Inlet Manifold	1	V237FB	
63	Manifold Bolt	12	V251D	
64	Manifold Washer	12	V302GA	
65	Manifold Nut	12	V354C	

U2ALB EXPLODED VIEWS

Standard with Versa-Rugged VR™ Diaphragm

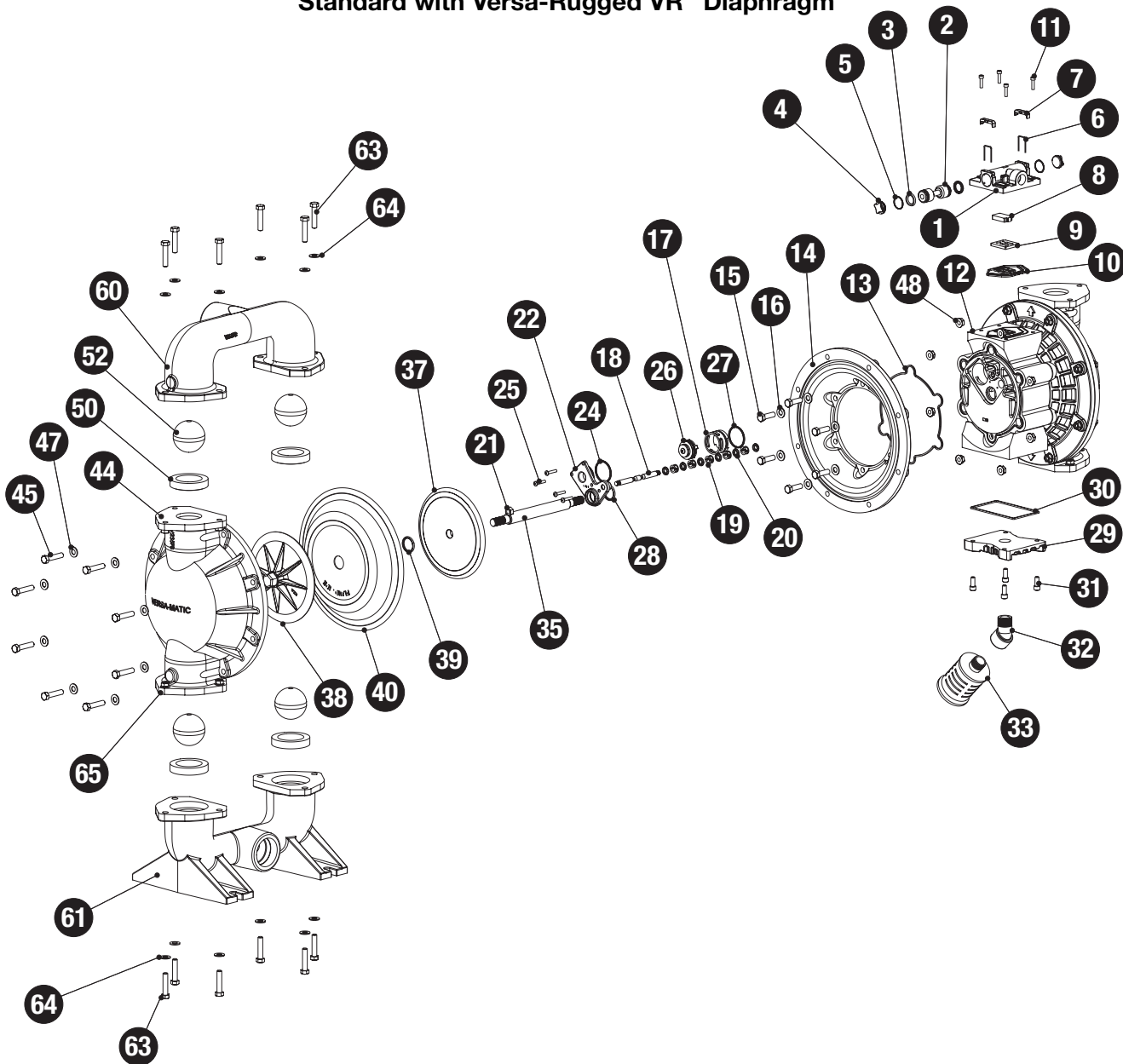

Optional Versa-Dome® Diaphragms

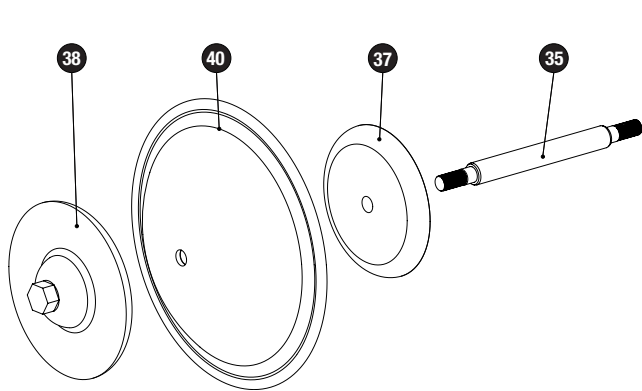

Optional Versa-Tuff® PTFE Diaphragms

